

Cisco NCS 4000 400 Gbps DWDM/OTN/Packet Universal Line Card

Contents

Product overview	3
Challenge and solution	4
Product description	5
Network applications - programmable ethernet transport	12
Licensing	13
Product specifications	13
Other specifications	15
Warranty information	19
Cisco Services for migrating converged IP + optical solutions	19
Cisco environmental sustainability	19
Cisco Capital	20
For more information	20
Document history	20

Product overview

The Cisco® Network Convergence System (NCS) 4000 400 Gbps Universal line card converges Dense Wavelength-Division Multiplexing (DWDM), Optical Transport Networking (OTN) and Packet services into a single line card. The Universal line card can be provisioned to provide any combination of 10 Gbps, 40 Gbps and 100 Gbps grey services as well as 100 Gbps, 150 Gbps and 200 Gbps DWDM services. The card has been engineered to be a Universal line card: all services and applications supported by NCS 4000 can be efficiently deployed using just this card, without stranding any bandwidth.

The Cisco NCS 4000 Universal line card dramatically enhances system density and performances delivering 400 Gbps capacity per slot (6.4 Tbps per NCS 4016 chassis), and the ability to map traffic across the different ports on the faceplate. Selecting the type of pluggable optics, on a port-by-port basis, defines the unique profile of each Universal line card:

- Up to 2x 200 Gbps Dense Wavelength-Division Multiplexing (DWDM) wavelengths using the CFP2 ports
- Up to 4x 100GE/OTU4 Client interfaces using the QSFP28 ports
- Up to 10x 40GE/OTU3 Client Interfaces using the QSFP+/QSFP28 ports
- Up to 40x 10GE/OTU2 Client Interfaces using the QSFP+/QSFP28 ports
- Any mix and combination of the above

The Cisco NCS 4000 400 Gbps Universal line card simplifies the integration and transport of 10 Gbps, 40 Gbps and 100 Gbps Ethernet and Optical Transport Unit (OTU) services for service provider and enterprise networks.

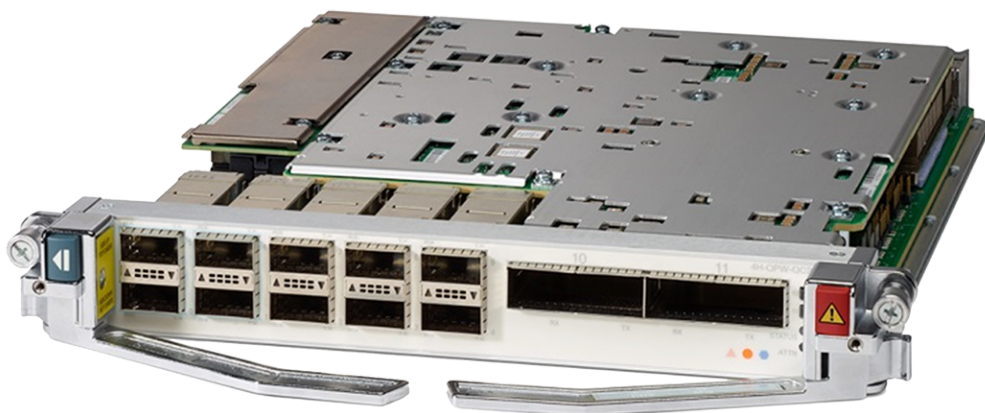

Figure 1.
Cisco® NCS 4000 400 Gbps WDM/OTN/Packet Universal Line Card

Challenge and solution

A growing number of network events are generated every day as billions of programmable devices connect to one another over the Internet. This imposes new expectations on network performance. As the Internet of Everything (IoE) builds, the role of the network to support, manage, and control these programmable device-driven events becomes critical as these tasks rapidly surpass the capacity of manual intervention. Networks must evolve to support new levels of virtualization, programmability, and performance. Networks must now scale not just bandwidth, but also compute and control functions to manage policies and generate the proper responses within the expected timeframe.

With just one line card, the Cisco NCS 4000 400 Gbps DWDM/OTN/Packet Universal line card, network operators are able to grow with programmability, scale, and convergence across the photonic, OTN, and packet switching layers. Combined, the Cisco NCS 4000 and the 400 Gbps Universal line card provide network operators with an enhanced architectural approach to profitably deliver innovative and flexible services across an evolved programmable network, while simultaneously increasing resiliency and dramatically reducing capital expenditures.

Benefits

The Cisco NCS 4000 400 Gbps DWDM/OTN/Packet Universal line card provides multiple benefits in term of **Flexibility, Performance, Savings** and **Density** improvements.

Flexibility

A single 400 Gbps Universal line card providing any mix of photonic, OTN and Packet services, supporting rates that include 10 Gbps, 40 Gbps, 100 Gbps grey services. The NCS 4000 Universal line card also provides two 200 Gbps 16-QAM DWDM Long Haul transmission ports through the CFP2 ACO pluggables.

Performance improvement

Incorporating the latest generation of Digital Signal Processor (DSP) technology dramatically increases the performance of 100 Gbps QPSK and 200 Gbps 16-QAM optical transport. Support of 8-QAM modulation format will also further enhance the capability of the NCS 4000 system, enabling the right tradeoff between fiber capacity and un-regenerated transmission distance.

Savings

The ability to configure multiple grey and DWDM ports from a single line card dramatically reduces operational costs. With only one line card to maintain, forecasting and ordering are greatly simplified, sparing is significantly reduced, and designing network expansion is far less complex, resulting in accelerated time-to-market for new services.

Density

Configuring a single NCS 4016 chassis with sixteen 400 Gbps Universal line cards delivers 6.4 Tbps of grey, OTN and Packet service capacity, including thirty-two High Speed Coherent DWDM Interfaces, all in a single 24 Rack Unit (RU) chassis - 12.8 Tbps in one full rack.

Figure below shows the deployment flexibility of the Universal OTN/DWDM/MPLS linecard with degrees of flexibility across technology and bandwidth requirements to enable the cost savings and allow for a smooth technology migration and adoption.

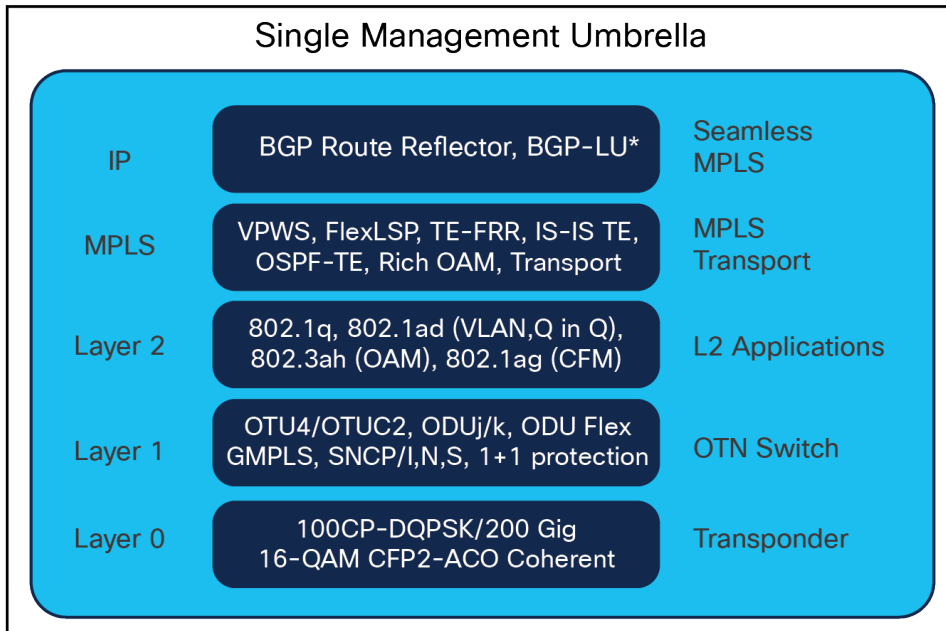

Figure 2.
Deployment Options

Product description

The Cisco NCS 4000 400 Gbps DWDM/OTN/Packet Universal line card provides two High Speed CFP2-based DWDM ports, six QSFP+ based ports supporting 40 Gbps or four 10 Gbps services, and four QSFP+ or QSFP28 based ports that can support 40 Gbps, four 10 Gbps QSFP+ or 100 Gbps services.

The Universal line card supports 400 Gbps of OTN switching functionality (from ODU-0 up to ODU-4) as well as of Carrier Ethernet and MPLS switching functionalities and is directly connected through the backplane to the NCS 4000's Agnostic Switching Fabric line card.

WDM interfaces

The Cisco NCS 4000 400 Gbps DWDM/OTN/Packet Universal Line Card provides two High Speed CFP2-based DWDM ports capable of transmitting 100 Gbps, 150 Gbps or 200 Gbps carriers, which can be transported independently across the network or combined into a 400 Gbps dual-wavelength super-channel.

Each High Speed port can be configured to support:

- 100 Gbps Coherent DWDM transmission with QPSK modulation
- Hardware support for 150 Gbps Coherent DWDM transmission with 8-QAM modulation
- 200 Gbps Coherent DWDM transmission with 16-QAM modulation

The different modulation schemes listed above are software configurable to deliver the ideal tradeoff between reach and transport capacity per wavelength. The primary modulation schemes leveraged today for DWDM transmission are QPSK, 8-QAM and 16-QAM. The constellation diagrams for these modulation types are illustrated in Figure 3.

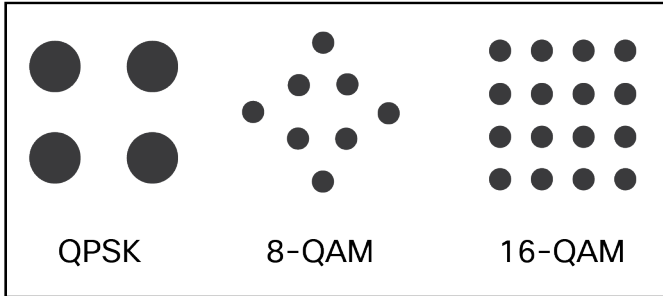

Figure 3. Constellation diagrams for QPSK, 8-QAM and 16-QAM

While higher order modulation formats provide higher spectral efficiency, they generally require more Optical Signal-to-Noise Ratio (OSNR) resulting in reduced un-regenerated reach.

Figure 4 shows the relationship of reach vs. spectral efficiency for QPSK, 8-QAM and 16-QAM modulation when using ITU-T G.652 SMF or ITU-T G.655 LEAF fiber and with varying channel spacing.

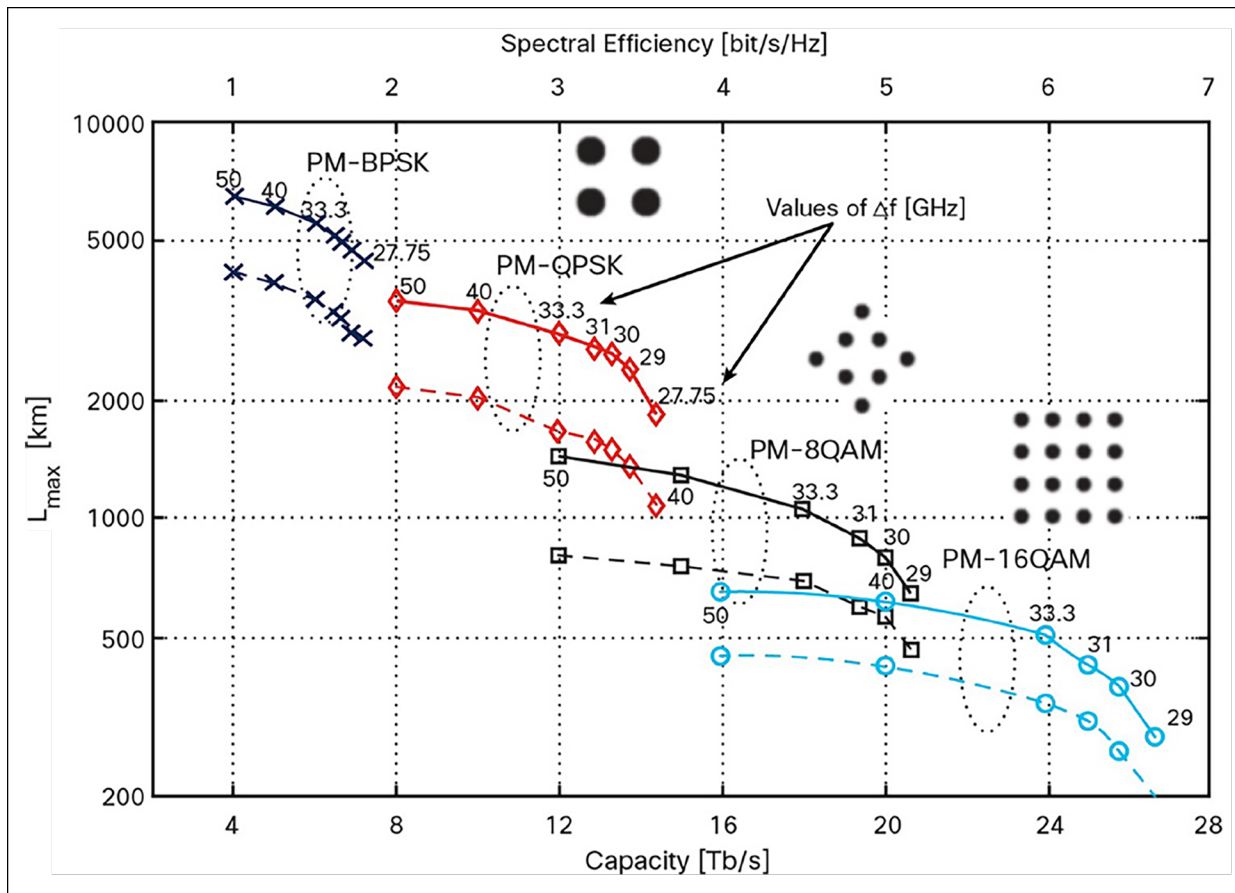

Figure 4. The chart provides capacity (Tbps) and Spectral Efficiency (bit/s/Hz) VS Maximum Reach (L_{max}) for different modulation schemes. SMF is represented in solid lines and LEAF is represented in dashed lines.

Cisco Coherent Transmission technology greatly enhances the reach and reliability of transport performance while providing the flexibility to select the optimal modulation scheme for a specific application. The primary benefits of Cisco Coherent technology include:

- Very strong OSNR performance
- Outstanding chromatic dispersion robustness, avoiding any additional cost related to optical chromatic dispersion compensation equipment
- Extended polarization mode dispersion robustness
- Very high spectral efficiency, allowing wavelengths to be transmitted across a large number of Reconfigurable Optical Add/Drop Multiplexers (ROADMs)

Trunk CFP2 WDM pluggables

The Cisco NCS 4000 400 Gbps DWDM/OTN/Packet Universal line card supports Analog Coherent Optical (ACO) CFP2 WDM pluggables, featuring software-provisionable tunability across the full C-band. Both 50 GHz channels spacing (supporting 96 Nyquist shaped wavelengths) and grid-less 100MHz tuning steps are supported. Different modulation schemes are also software configurable as described earlier.

Client ports

The Cisco NCS 4000 400 Gbps DWDM/OTN/Packet Universal line card supports the following client services:

- 10 Gbps (leveraging 4x10 Gbps QSFP+) - 10GE LAN-PHY, OTU-2, OC-192/STM-64 services are available. and 8G/16G FC services are planned for in a future software release.
- 40 Gbps (leveraging 40 Gbps QSFP+) - 40GE LAN-PHY and OTU-3 services are available.
- 100 Gbps (leveraging 100 Gbps QSFP28) - 100GE and OTU-4 services are available.

Software configurable FEC option

Four different Software Defined Forward Error Correction (SD-FEC) options are supported by the Cisco NCS 4000 400 Gbps DWDM/OTN/Packet Universal line card:

- 25% Overhead (OH) for maximum performance.
- 25% Overhead (OH) with Differential Encoding.
- 15% Overhead (OH) to minimize filtering impairment.
- 15% Overhead (OH) with Differential Encoding.

The configuration of the SD-FEC overhead can be done through the available management interfaces.

OTN switching

The Cisco NCS 4000 400 Gbps DWDM/OTN/Packet Universal line card provides full ITU G.872-compliant OTN switching functions. It supports ODU-0 to ODU-4 multilayer switching and grooming including nested OTN switching. The Universal line card is capable of supporting up to 2-level ODU-4, ODU-3, ODU-2, ODU-1, ODU-0, and ODU-Flex switching functions by interconnecting with the centralized agnostic switch fabric. Ethernet Signals are mapped into ODU container as described in Table 1.

Table 1. OTN line-card mapping

Rate	Mapping
10 Gigabit Ethernet	G.Sup43 7.1/G.709 17.2.4: CBR10.3G over OPU2e G.709 17.4: GFP-F over OPU2 G.Sup43 7.3/G.709 17.4.1: GFP-F over Extended OPU
40 Gigabit Ethernet	BMP or GMP over OPU3 CBR or GFP-F over OPUF
100 Gigabit Ethernet	GFP-F or GMP over OPU4 CBR or GFP-F over OPUF

The Cisco NCS 4016 system, equipped with 400 Gbps DWDM/OTN/Packet Universal line card, supports single-chassis switching of 6.4 Tbps fully non-blocking at ODU-0 level (5120 ODU-0 or ODU-Flex data units) while the Cisco NCS 4009 system supports single-chassis switching of 3.6 Tbps fully non-blocking at ODU-0 level (2880 ODU-0 or ODU-Flex data units).

The NCS 4000 is ITU G.709 Operations, Administration, and Maintenance (OAM)-compliant, with six levels of Tandem Connection Monitoring (TCM) support.

OTN configuration, provisioning, and protection are managed by a Generalized MPLS (GMPLS)-based OTN control plane supporting an embedded User-Network Interface (UNI) as the communication interface between control planes managing different transport layers within the same system. The control-plane instance runs inside the optical domain (overlay network scenario), providing an external UNI interface to client nodes for invocation of on-demand services.

As an extension of the Cisco nLight Control Plane Protocol, an OTN circuit between ingress and egress nodes can be established statically or dynamically using Resource Reservation Protocol (RSVP) signaling. An OTN circuit is established and maintained as a Label Switched Path (LSP) between the ingress and egress LSRs, switched through transit LSRs.

Packet features

The Cisco NCS 4000 400 Gbps DWDM/OTN/Packet Universal line card supports packet features as defined in Table 2 on a per-ODU, or on a per-interface basis.

Table 2. Packet feature-set

Functionality	Featured Mechanism
Layer 2 transport	Carrier Ethernet, MPLS
Layer 2 and Layer 2+ services	Carrier Ethernet: EPL, EVPL MPLS-TE: P2P circuits (VPWS) Associated Bi-directional Channel with Sub-50ms protection
Ethernet virtual circuit	IEEE 802.1q, IEEE 802.1ad
IGP	OSPF-TE and IS-IS

Functionality	Featured Mechanism
Quality of service (per port)	Policing, queuing/shaping Single-rate, dual-color policer (1R2C) Dual-rate, three-color policer (2R3C)
Ethernet OAM	IEEE 802.1ag CFM IEEE 802.3ah EFM
Sync-E	ITU-T G.8261 ITU-T G.8262

Management

The Cisco NCS 4000 system provides comprehensive management capabilities to support Operations, Administration, Maintenance, and Provisioning (OAM&P) through the integrated Cisco Transport Controller craft interface and it is also supported by Cisco Evolved Programmable Network Manager (EPN-M) Network Management System (NMS).

The card features provisionable digital wrapper (G.709) functionality, providing per-wavelength performance management capabilities, especially for services transported transparently across the network. Without the digital wrapper functions, a carrier transporting a service transparently would be unable to identify network impairments that may degrade the transported signal and violate the SLA agreements. The digital wrapper's Generic Communication Channel (GCC) provides a separate communications channel on a per-wavelength basis to be used when transparent signals are transported. GCC allows the Cisco NCS 4000 system to extend its advanced network auto discovery capabilities to DWDM-based services. The integrated Cisco Transport Controller (CTC) craft manager and Cisco EPN-M provide the user with OAM&P functionalities for the system.

Performance monitoring

The Cisco NCS 4000 400 Gbps DWDM/OTN/Packet Universal line card provides Multi-Layer Performance Monitoring (PM) at Layer-0/1/2 and 3. The digital wrapper channel is monitored according to G.709 Optical Transport Network (OTN) and G.8021 standards. Performance monitoring of optical parameters on the client and DWDM line interface include Loss of Signal (LOS), laser bias current, transmit optical power, and receive optical power. Calculation and accumulation of the performance monitoring data are supported in 15-minute and 24-hour intervals as per G.7710.

Physical system parameters measured at the wavelength level, such as mean polarization mode dispersion, accumulated chromatic dispersion, or received optical signal to noise ratio, are also included in the set of performance monitoring parameters.

Ethernet statistics are available to provide performance monitoring of Layer 2 services.

These can greatly simplify troubleshooting operations and enhance the set of data that can be collected directly from the equipment. A detailed list of performance monitors is given in following Tables.

Table 3. OTN performance monitoring

G.709 Performance Monitoring	OTUk (Section) Monitoring (Near End and Far End)	ODUk (Path) Monitoring (Near End and Far End)	TCM Monitoring (Near End and Far End)
Number of Background Block Errors (BBE)	BBE-SM	BBE-PM	BBE-PM
Background Block Errors Ratio (BBER)	BBER-SM	BBER-PM	BBER-PM
Number of Errored Seconds (ES)	ES-SM	ES-PM	ES-PM
Errored Seconds Ratio (ESR)	ESR-SM	ESR-PM	ESR-PM
Number of Severely Errored Seconds (SES)	SES-SM	SES-PM	SES-PM
Severely Errored Seconds Ratio (SESR)	SESR-SM	SESR-PM	SESR-PM
Number of Unavailable Seconds (UAS)	UAS-SM	UAS-PM	UAS-PM
Number of Failure Counts (AIS/RFI detected) (FC)	FC-SM	FC-PM	FC-PM

Table 4. Ethernet stats

Counter	Description
rxTotalPkts	The number of received packets.
etherStatsPkts	The total number of packets (including bad packets, broadcast packets, and multicast packets) received.
EtherStatsOctets	The total number of octets of data (including those in bad packets) received on the network (excluding framing bits but including FCS octets).
etherStatsOversizePkts	The total number of packets received that were longer than 1518 octets (excluding framing bits but including FCS octets) and were otherwise well formed.
dot3StatsFCSErrors	The number of frames with frame check errors.
dot3StatsFramesTooLong	The number of packets at least 64 octets long, without a bad Frame Check Sequence (FCS), where the 802.3 length/type field did not match the computed DATA field length.
etherStatsJabbers	The total number of packets received that were longer than 1518 octets (excluding framing bits, but including FCS octets), and had either a bad Frame Check Sequence (FCS) with an integral number of octets (FCS Error) or a bad FCS with a non-integral number of octets (Alignment Error).
etherStatsPkts64Octets	The total number of packets (including bad packets) received that were 64 octets in length (excluding framing bits but including FCS octets).
etherStatsPkts65to127Octets	The total number of packets (including bad packets) received that were between 65 and 127 octets in length inclusive (excluding framing bits but including FCS octets).

Counter	Description
etherStatsPkts128to255Octets	The total number of packets (including bad packets) received that were between 128 and 255 octets in length inclusive (excluding framing bits but including FCS octets).
etherStatsPkts256to511Octets	The total number of packets (including bad packets) received that were between 256 and 511 octets in length inclusive (excluding framing bits but including FCS octets).
etherStatsPkts512to1023Octets	The total number of packets (including bad packets) received that were between 512 and 1023 octets in length inclusive (excluding framing bits but including FCS octets).
etherStatsPkts	The total number of packets (including bad packets, broadcast packets, and multicast packets) received.
etherStatsPkts1024to1518Octets	The total number of packets (including bad packets) received that were between 1024 and 1518 octets in length inclusive (excluding framing bits but including FCS octets).
ifInUcastPkts	The number of packets, delivered by this sub-layer to a higher (sub-)layer, which were not addressed to a multicast or broadcast address at this sub-layer.
ifInMulticastPkts	The total number of multicast frames received error-free.
ifInBroadcastPkts	The number of packets delivered to a higher sublayer and addressed to a broadcast address at this sublayer.
IfOutUcastPkts	The total number of packets that higher-level protocols requested be transmitted, and which were not addressed to a multicast or broadcast address at this sub-layer, including those that were discarded or not sent.
IfOutMulticastPkts	The number of multicast frames transmitted error-free.
IfOutBroadcastPkts	The number of packets requested by higher-level protocols and addressed to a broadcast address at this sublayer, including those not transmitted.
txTotalPkts	The number of transmitted packets.
ifOutOctets	The total number of octets transmitted out of the interface, including framing characters.

Network applications - programmable ethernet transport

The Cisco NCS 4000 400 Gbps DWDM/OTN/Packet Universal line card provides a highly scalable, cost optimized solution to aggregate and transport a large variety of services, expanding from pure OTN transport to a more sophisticated and feature-rich MPLS transport applications.

Figure 5 shows the standard OTN switching application supported by NCS 4000 solution.

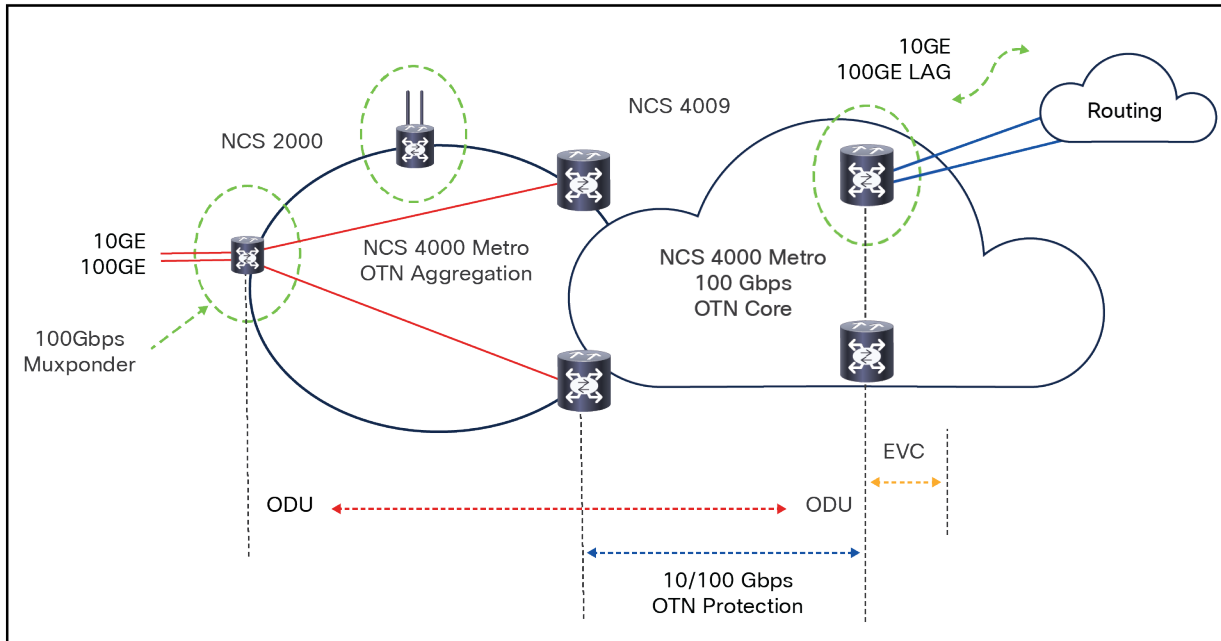

Figure 5.
OTN switching application

Figure 6 describes Packet Optical Aggregation use cases for the associated LSP technology, which provides the following benefits:

- Predictable, Deterministic Transport-Centric (1:1 LSP Redundancy)
- Resiliency – Sub-50 msec
- Rich OAM
- Fault Propagation, Connectivity Verification (MPLS-TP OAM)
- Statistical Multiplexing
- Programmable (RSVP-TE Extensions)
- MPLS Scalability

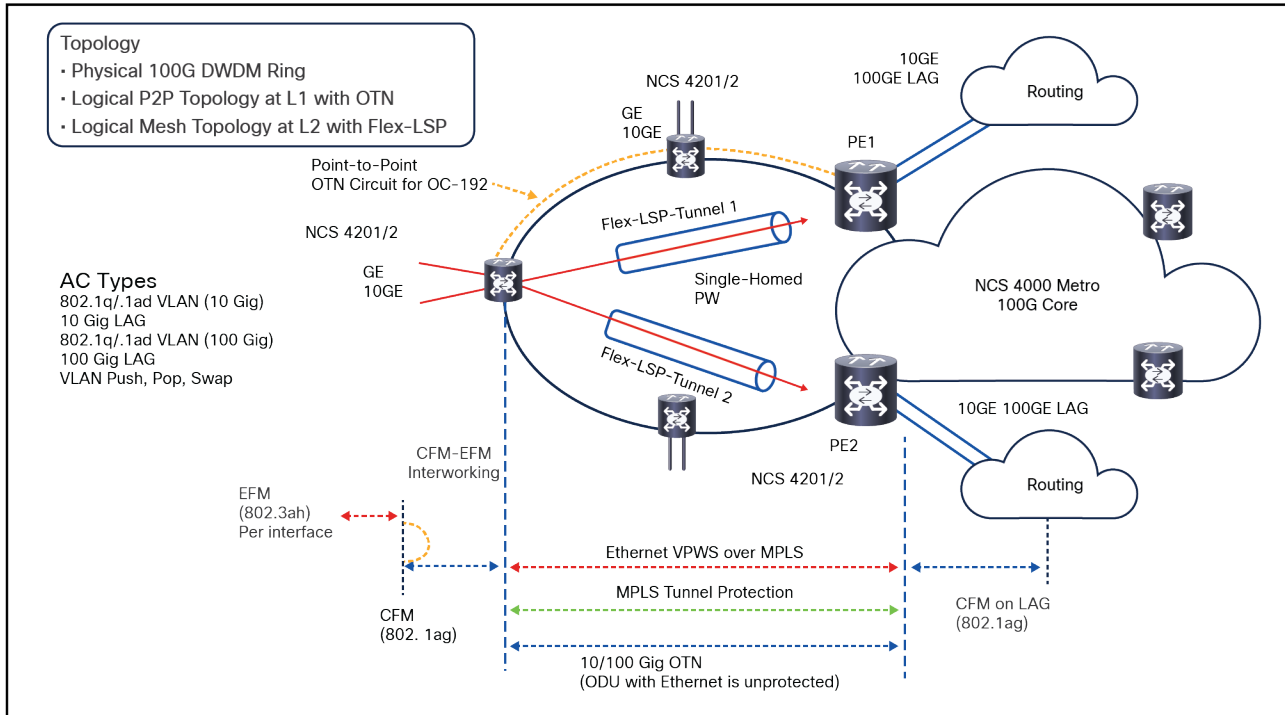

Figure 6.
Packet optical aggregation application

Licensing

The NCS4k Universal OTN/WDM/Packet Linecard can be deployed with multilayer functionality and bandwidth on an as-needed basis for unprecedented deployment flexibility.

- Base License – Hardware, OTN functionality plus 100 Gbps of aggregate client/trunk bandwidth.
- WDM License – Enables Coherent DWDM functionality at 100 Gig QPSK/200 Gig 16-QAM
- Packet License – Enables L2/MPLS functionality on the linecard.
- Bandwidth License – Enables additional aggregate client/trunk bandwidth beyond the base license.

Product specifications

Compact design

- Single-slot card design for high-density, 400 Gbps solutions
- Up to 16 cards per Cisco NCS 4016 shelf assembly, or 9 cards per NCS 4009 shelf assembly

Regulatory compliance

Table 5 lists regulatory compliance information for the NCS 4000 400 Gbps DWDM/OTN/Packet Universal line card. Note that all compliance documentation may not be completed at the time of product release. Please check with your Cisco sales representative for countries other than Canada, the United States, and the European Union.

Table 5. Regulatory compliance

ANSI System	ETSI System
Countries and Regions Supported	
<ul style="list-style-type: none"> • Canada • United States • Korea • Japan • European Union 	<ul style="list-style-type: none"> • European Union • Africa • CSI • Australia • New Zealand • China • Korea • India • Saudi Arabia • South America
EMC (Class A)	
<ul style="list-style-type: none"> • ICES-003, 2004 • GR-1089-CORE Issue 4, NEBS EMC and Safety, June 2006 • FCC 47CFR15, 2007 	<ul style="list-style-type: none"> • ETSI EN 300 386 V1.4.1 (2008-04) Telecommunication network equipment EMC requirements (Note: EMC-1) • CISPR22:2008 and EN55022:2006/A1:2007 Information Technology Equipment (Emissions) (EMC-2) • CISPR24:1997/A1:2001/A2:2002 and EN55024:1998/A1:2001/A2:2003: Information Technology Equipment – Immunity characteristics – Limits and Methods of Measurement (test levels)
Safety	
<ul style="list-style-type: none"> • CSA C22.2 #60950-1 – Edition 7, March 2007 • UL 60950-1 – Edition 2, March 2007 • GR-1089-CORE Issue 4, NEBS EMC and Safety, June 2006 	<ul style="list-style-type: none"> • UL 60950-1 – Edition 2, March 2007 • IEC 60950-1 Information technology equipment Safety Part 1: General requirements – Edition 2, 2005 and National Differences as per CB Bulletin 112A • IEC/EN 60950-1 (2006/10) with Amendment 11:2004 to EN 60950-1:2001, 1st Edition and National Differences as per CB Bulletin 112A • EN 60950-1, Edition 2 (2006) Information technology equipment – Safety – Part 1: General requirements • CE Safety Directive: 2006/95/EC
Laser	
<ul style="list-style-type: none"> • UL 60950-1 – Edition 2, March 2007 • IEC 60825-1: 2001 Ed.1.2 (incl. am1+am2) Safety of laser products Part 1: Equipment classification, requirements and users guide • IEC60825-2 Ed.3 (2004) Safety of laser products Part 2: Safety of optical fiber communication systems + A1:2006 	<ul style="list-style-type: none"> • IEC 60825-1:2001 Ed.1.2 (incl. am1+am2) Safety of laser products Part 1: Equipment classification, requirements and users guide • IEC60825-2 Ed.3 (2004) Safety of laser products Part 2: Safety of optical fibre communication systems + A1:2006 • 21CFR1040 (2008/04) (Accession Letter and CDRH Report) Automatic Laser Shutdown and restart (ALS) according to ITU-T G.664 (03/06). Guidance for Industry and FDA Staff (Laser Notice No. 50), June 2007 • Laser Products: Conformance with IEC 60825-1 and IEC 60601-2-22: Guidance for Industry and FDA Staff (Laser Notice No. 50), June 2007
Environmental	
<ul style="list-style-type: none"> • GR-63-CORE Issue 3, Network Equipment Building Standards (NEBS) Physical Protection, March 2006 	<ul style="list-style-type: none"> • ETS 300-019-2-1 V2.1.2 (Storage, Class 1.1) • ETS 300-019-2-2 V2.1.2 (1999-09): Transportation, Class 2.3 • ETS 300-019-2-3 V2.2.2 (2003-04): Operational, Class 3.1E

ANSI System	ETSI System
Optical	
<ul style="list-style-type: none"> • GR-253-CORE – Issue 04 • ITU-T G.691 	<ul style="list-style-type: none"> • ITU-T G.709 • ITU-T G.975
Quality	
<ul style="list-style-type: none"> • TR-NWT-000332, Issue 4, Method 1 calculation for 20-year Mean Time Between Failure (MTBF) 	
Miscellaneous	
<ul style="list-style-type: none"> • GR-1089-CORE Issue 4, NEBS EMC and Safety (June 2006) (Note: NEBS-1) • GR-63-CORE Issue 3, NEBS Physical Protection (March 2006) (Note: NEBS-2) • ATT-TP-76200: 2008 • ANSI T1.315-2001 • GR-499: 2004 Transport Systems Generic Requirements (TSGR): Common Requirements 	

Other specifications

Table 6 lists system requirements for the Cisco NCS 4000 400-Gbps WDM/OTN/Packet Combo Line Card. Table 7 provides the DWDM specifications, Table 6 details receive-side optical performances, Table 8 lists performance monitoring parameters, Table 9 provides card specifications, and Table 10 gives ordering information. Please Refer to CFP2 WDM Datasheet for Physical parameters.

Table 6. System requirements

Component	Cisco NCS 2000M6
Processor	NCS4K-RP-K9
Shelf assembly	Cisco NCS 4016, NCS4009
System software	Release 6.1.22 or later

Table 7. DWDM specifications

Parameter	Value
Baud rate	31.3793 Gbaud ±20 ppm (OTU4 with SD-FEC 15% OH) 34.1660 Gbaud ±20 ppm (OTU4 with SD-FEC 25% OH)
Automatic laser shutdown and restart	ITU-T G.664 (06/99)
Nominal wavelengths (Tnom)	Full-tunable between 1528.77 and 1567.13 nm (C-Band)
Optical Transmitter	
Type	CP-QPSK modulation format CP-16QAM modulation format Laser Stability +/- 1.5 GHz
Optical Receiver	
Chromatic dispersion tolerance (DLRmax)	+/- 70,000, ps/nm with CP-QPSK formats +/- 25,000, ps/nm with 16-QAM
DGD Tolerance	100 ps

Table 8. DWDM receive-side optical performances

Modulation	FEC Type	Post-FEC BER	Input Power Sensitivity*	DGD	B2B OSNR (0.1 nm RWB)
CP-QPSK	SD-FEC (25% OH)	<10E (-15)	0 to -14dBm	-	11.3 dB
CP-QPSK	SD-FEC (15% OH)	<10E (-15)	0 to -14dBm	-	11.8 dB
CP-16QAM	SD-FEC (25% OH)	<10E (-15)	0 to -14dBm	-	19.6 dB
CP-16QAM	SD-FEC (15% OH)	<10E (-15)	0 to -14dBm	-	20.3 dB

* Receiver Sensitivity can be extended down to -20dBm allocating additional OSNR margins

Table 9. Layer 1 performance monitoring parameters

Area	Parameter Name	Description
FEC	Bit errors	Number of corrected bit errors
	Uncorrectable words	Number of uncorrectable words
Trunk optical performance monitoring	OPT	Transmitter optical power
	LBC	Transmitter laser bias current
	OPR	Receiver optical power
	RCD	Residual chromatic dispersion
	PMD	Mean polarization mode dispersion
	OSNR	Optical signal-to-noise ratio, calculated with 0.5 nm RBW
	SOPMD	Second Order PMD (SOPMD Estimation
	SOPCR	Polarization Change Rate Estimation
	PDL	Polarization Dependent Loss (PDL) Estimation

Table 10. Card specifications

Management	
Card LEDs	
Failure (FAIL)	Red
Active/standby (ACT/STBY)	Green/yellow
Signal Fail (SF)	Yellow
Client port LEDs (per port)	
Active input signal	Green
DWDM port LEDs	
Active input signal	Green
Output wavelength	Green
Power (including pluggable)	
Typical	401 W
Maximum	534 W
Physical	
Dimensions	Occupies 1 slot
Weight	7.7 lb. (3.5 kg)

Management

Reliability and availability

Mean Time Between Failures (MTBF)	250,440 hrs.
Storage temperature	-40°C to 70°C (-40°F to 158°F)
Operating temperature	
Normal	0°C to 40°C (32°F to 104°F)
Short-term ¹	-5°C to 55°C (23°F to 131°F)
Relative humidity	
Normal	5% to 85%, noncondensing
Short-term ¹	5% to 90% but not to exceed 0.024 kg water/kg of dry air

¹ Short-term refers to a period of not more than 96 consecutive hours and a total of not more than 15 days in 1 year (a total of 360 hours in any given year, but no more than 15 occurrences during that 1-year period). The values shown are valid for M6 or M2 chassis.

Table 11. Ordering information

Part Number	Description
NCS4K-4H-OPW-QC2=	NCS 4000 400G WDM w/Packet/OTN - 10x QSFP + 2x CFP2 Line Card
NCS4K-4H-OPW-LO=	NCS 4000 400G Packet/OTN/WDM - QSFP28/CFP2 - Lic. 100G OTN
S-CFP2-WDM-LIC=	SW License for WDM CFP2 Pluggable - 100G QPSK 15% SD FEC
S-NCS4K-100G-LIC=	SW license for 100G Bandwidth Licenses
S-NCS4K-POTS=	License POTS - CE and MPLS - for NCS 4000 Packet Line Card

Table 12. Supported Pluggables

Part Number	Description	SW Release availability
ONS-CFP2-WDM=	100G QPSK/200G 16-QAM - WDM CFP2 Pluggable	IOS-XR 6.1.22
ONS-QSFP28-LR4=	100Gbps Multi-rate QSFP28, LR	IOS-XR 6.1.22
ONS-QSFP-4X10-MLR=	100GBASE LR4 QSFP Transceiver, LC, 10km over SMF	IOS-XR 6.1.22
QSFP-40G-LR4=	QSFP 40GBASE-LR4 Transceiver Module, LC, 10KM	IOS-XR 6.1.22
QSFP-40G-SR4=	40GBASE-SR4, 4 lanes, 850 nm MM	IOS-XR 6.1.22
QSFP-40G-ER4=	QSFP 40GBASE-ER4 Transceiver Module, LC, 40KM	IOS-XR 6.1.22
QSFP-40G-CSR4=	QSFP 4x10GBASE-SR Transceiver Module, MPO, 300M	IOS-XR 6.1.22

Part Number	Description	SW Release availability
QSFP-100G-ER4L-S=	100GBASE QSFP Transceiver, 25-40KM reach over SMF, Duplex LC	IOS-XR 6.1.42
QSFP-100G-SM-SR=	100GBASE CWDM4 Lite QSFP Transceiver, 2km over SMF, 10-60C	IOS-XR 6.1.42
ONS-QSFP-4X10-MER=	4x10Gbps Multi-rate QSFP+, ER	IOS-XR 6.5.25
QSFP-100G-LR4-S=	100GBASE LR4 QSFP Transceiver, LC, 10km over SMF	IOS-XR 6.5.28
QSFP-100G-FR-S	100G QSFP28 Transceiver 100G-FR, 2km SMF, duplex, LC	IOS-XR 6.5.32
QSFP-100G-ZR4-S	100GBASE QSFP Transceiver, 80KM reach over SMF, Duplex LC	IOS-XR 6.5.35

Warranty information

Find warranty information on Cisco.com at the [Product Warranties](#) page

Cisco Services for migrating converged IP + optical solutions

Services from Cisco and our partners help you get the most value from your investments in the Cisco converged IP + Optical solution, quickly and cost-effectively. We can help you design, implement, and validate your solution to speed migration and cutover. Coordinate every step through to interworking. Strengthen your team. And make the most of tomorrow's opportunities. Learn more at <https://www.cisco.com/go/spservices>.

Cisco environmental sustainability

Information about Cisco's environmental sustainability policies and initiatives for our products, solutions, operations, and extended operations or supply chain is provided in the "Environment Sustainability" section of Cisco's [Corporate Social Responsibility](#) (CSR) Report.

Reference links to **information about key environmental sustainability topics** (mentioned in the "Environment Sustainability" section of the CSR Report) are provided in the following table:

Sustainability Topic	Reference
Information on product material content laws and regulations	Materials
Information on electronic waste laws and regulations, including products, batteries, and packaging	WEEE compliance

Reference links to **product-specific environmental sustainability information** that is mentioned in relevant sections of this data sheet are provided in the following table:

Sustainability Topic	Reference
General	
Countries and Regions Supported	Table 5: Regulatory Compliance
Power	
Power (Including Pluggable)	Table 10: Card Specifications
Material	
Weight	Table 10: Card Specifications

Cisco Capital

Flexible payment solutions to help you achieve your objectives

Cisco Capital makes it easier to get the right technology to achieve your objectives, enable business transformation and help you stay competitive. We can help you reduce the total cost of ownership, conserve capital, and accelerate growth. In more than 100 countries, our flexible payment solutions can help you acquire hardware, software, services and complementary third-party equipment in easy, predictable payments. [Learn more](#).

For more information

For more information about the Cisco Network Convergence System (NCS) 4000, visit <https://www.cisco.com/go/ncs4000> or contact your local Cisco account representative.

Document history

New or revised topic	Described in	Date
Pluggable Supported List	Table 12: Supported Pluggables	March 4, 2024

Americas Headquarters
Cisco Systems, Inc.
San Jose, CA

Asia Pacific Headquarters
Cisco Systems (USA) Pte. Ltd.
Singapore

Europe Headquarters
Cisco Systems International BV Amsterdam,
The Netherlands

Cisco has more than 200 offices worldwide. Addresses, phone numbers, and fax numbers are listed on the Cisco Website at <https://www.cisco.com/go/offices>.

Cisco and the Cisco logo are trademarks or registered trademarks of Cisco and/or its affiliates in the U.S. and other countries. To view a list of Cisco trademarks, go to this URL: <https://www.cisco.com/go/trademarks>. Third-party trademarks mentioned are the property of their respective owners. The use of the word partner does not imply a partnership relationship between Cisco and any other company. (1110R)