

Cisco UCS Virtual Interface Card 1227

Contents

Cisco Unified Computing System Overview	3
Product overview	3
Features and benefits	4
Network interface virtualization	5
Product specifications	9
System requirements	10
Warranty information	10
Cisco Unified Computing Services	10
Why Cisco?	10
Cisco Capital	11
For more information	11

Cisco Unified Computing System Overview

The Cisco Unified Computing System™ (Cisco UCS®) is a next-generation data center platform that unites computing, networking, storage access, and virtualization resources in a cohesive system designed to reduce Total Cost of Ownership (TCO) and increase business agility. The system integrates a low-latency, lossless 10-Gbps Ethernet unified network fabric with enterprise-class blade and rack x86-architecture servers. The system is an integrated, scalable, multichassis platform in which all resources participate in a unified management domain.

Product overview

The Cisco UCS Virtual Interface Card (VIC) 1227 is a dual-port Enhanced Small Form-Factor Pluggable (SFP+) 10-Gbps Ethernet and Fibre Channel over Ethernet (FCoE)-capable PCI Express (PCIe) modular LAN-on-motherboard (mLOM) adapter designed exclusively for Cisco UCS C-Series Rack Servers (Figure 1). New to Cisco rack servers, the mLOM slot can be used to install a Cisco VIC without consuming a PCIe slot, which provides greater I/O expandability. It incorporates next-generation Converged Network Adapter (CNA) technology from Cisco, providing investment protection for future feature releases. The card enables a policy-based, stateless, agile server infrastructure that can present up to 256 PCIe standards-compliant interfaces to the host that can be dynamically configured as either Network Interface Cards (NICs) or Host Bus Adapters (HBAs). In addition, the Cisco UCS VIC 1227 supports Cisco® Data Center Virtual Machine Fabric Extender (VM-FEX) technology, which extends the Cisco UCS fabric interconnect ports to virtual machines, simplifying server virtualization deployment.



Figure 1.
Cisco UCS VIC 1227

Features and benefits

Stateless and Agile

The personality of the card is determined dynamically at boot time using the service profile associated with the server. The number, type (NIC or HBA), identity (MAC address and World Wide Name [WWN]), failover policy, bandwidth, and Quality-of-Service (QoS) policies of the PCIe interfaces are all determined using the service profile. The capability to define, create, and use interfaces on demand provides a stateless and agile server infrastructure (Figure 2).

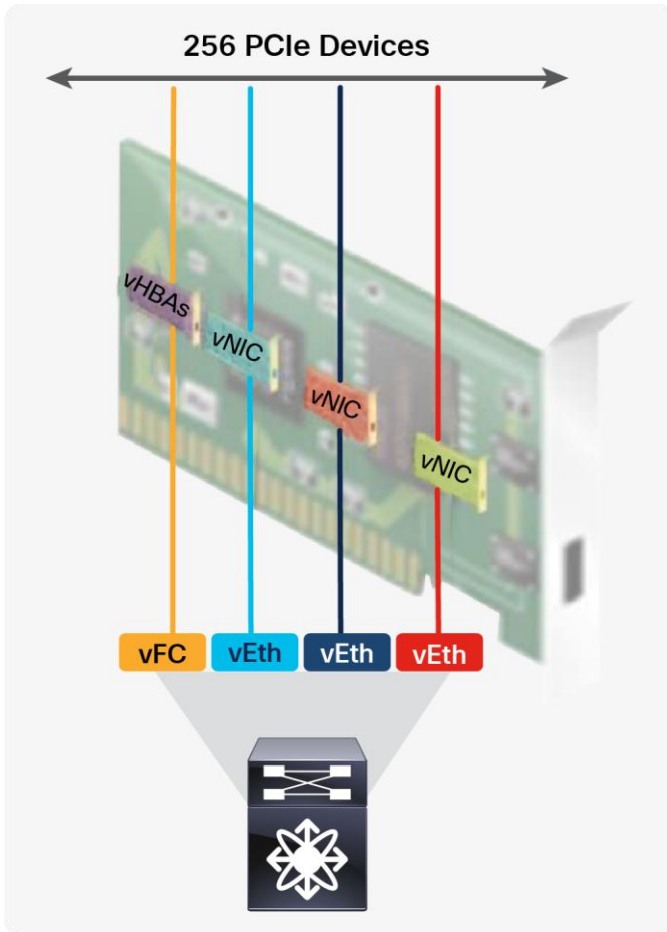

Figure 2.
Virtual Device Support on the Cisco UCS VIC 1227

Network interface virtualization

Each PCIe interface created on the VIC is associated with an interface on the Cisco UCS fabric interconnect, providing complete network separation for each virtual cable between a PCIe device on the VIC and the interface on the fabric interconnect (Figure 3).

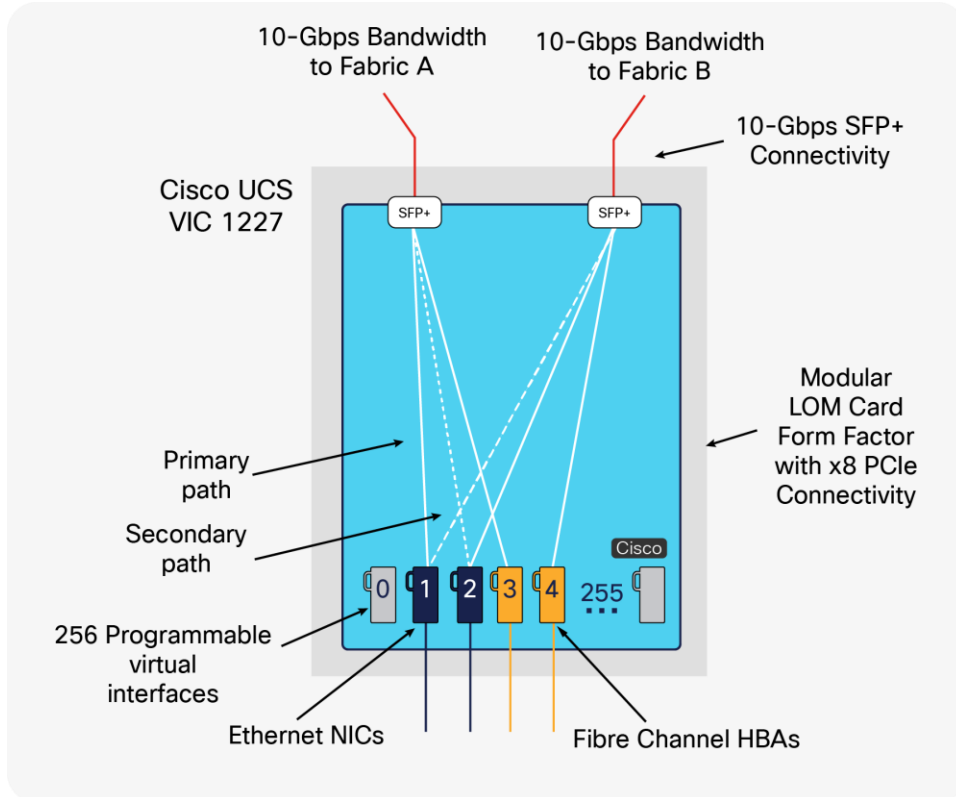

Figure 3.
Cisco UCS VIC 1227 Architecture

Cisco SingleConnect technology

Cisco SingleConnect technology provides an exceptionally easy, intelligent, and efficient way to connect and manage computing in the data center. Cisco SingleConnect technology dramatically simplifies the way that data centers connect to:

- Rack and blade servers
- Physical servers and virtual machines
- LAN, SAN, and management networks

The solution addresses the challenges of today's data center, and the result is a simple, intelligent, and efficient fabric:

- **Easy:** Cisco SingleConnect technology provides a “wire once and walk away” solution that eliminates traditional manual, time-consuming, error-prone processes and instead makes connecting servers to Cisco UCS fast and easy.
- **Intelligent:** The technology is intelligent because it uses a zero-touch model to allocate I/O connectivity (LAN, SAN, and management) across any type of server: physical rack and blade servers and virtual machines. The network intelligence helps Cisco UCS adapt to the needs of applications. Rather than limiting applications to specific servers, Cisco UCS makes it easy to run any workload on any server.
- **Efficient:** The technology is highly efficient because LAN, SAN, and management connections are shared over a single network, increasing utilization while reducing the number of moving parts compared to traditional approaches with multiple networks.

Cisco SingleConnect technology is implemented with an end-to-end system I/O architecture that uses Cisco Unified Fabric and Cisco Fabric Extender Technology (FEX Technology) to connect every Cisco UCS component with a single network and a single network layer. As customers expect from Cisco, the Cisco UCS I/O architecture is based on open standards and is highly reliable, available, and secure.

Cisco Data Center VM-FEX technology

Cisco Data Center VM-FEX technology extends fabric interconnect ports directly to virtual machines, eliminating software-based switching in the hypervisor. Cisco Data Center VM-FEX technology collapses virtual and physical networking infrastructure into a single infrastructure that is fully aware of the virtual machines' locations and networking policies (Figure 4). Cisco Data Center VM-FEX technology is implemented by Cisco VICs with a prestandard implementation of IEEE 802.1BR Port Extender.

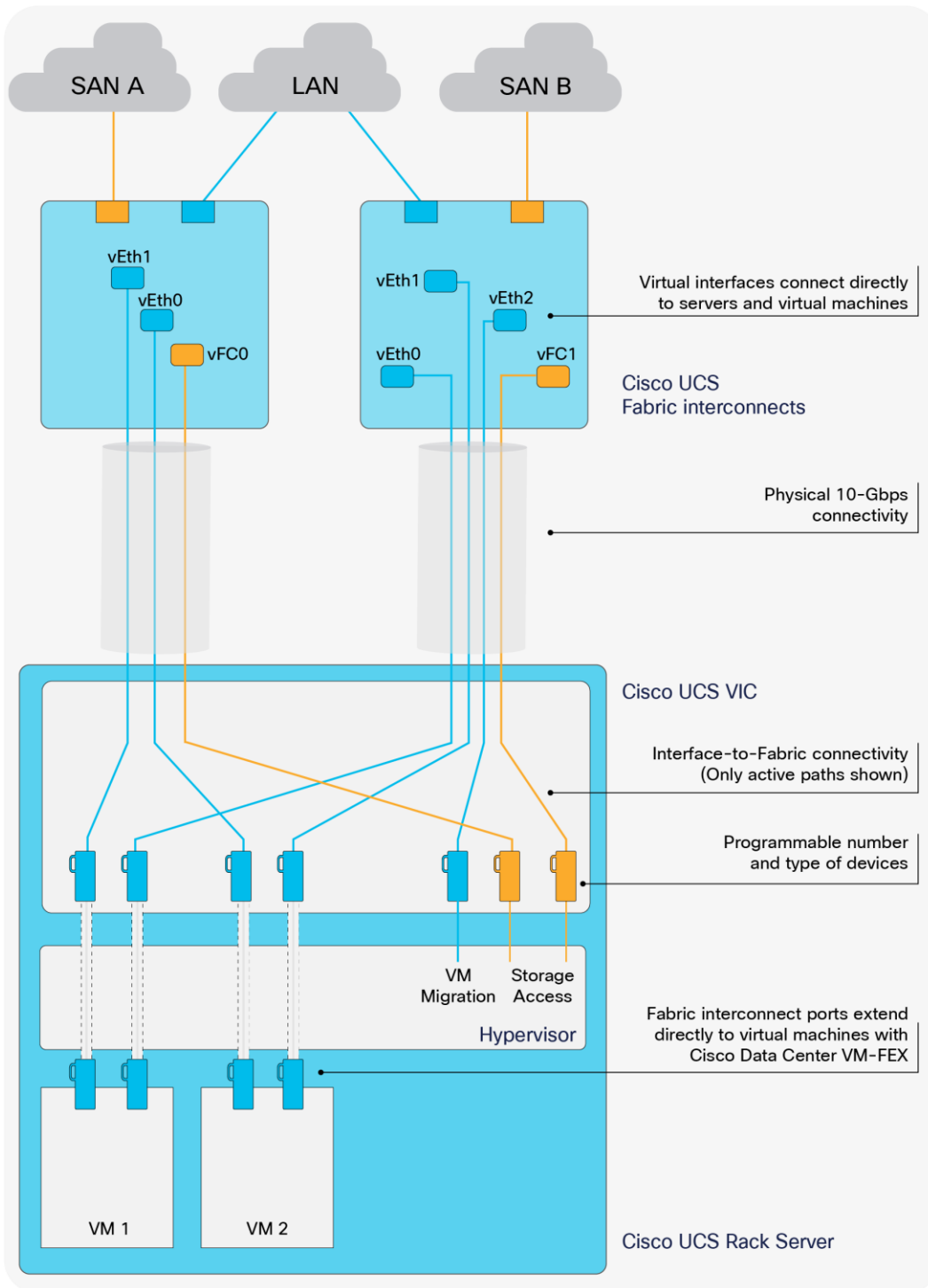

Figure 4.
Cisco Data Center VM-FEX with Cisco UCS VIC 1227

Table 1 summarizes the main features and benefits of the Cisco UCS VIC 1227.

Table 1. Features and benefits

Feature	Benefit
x8 PCIe Gen2 interfaces	Delivers greater throughput
2 x 10-Gbps unified I/O	<ul style="list-style-type: none"> • Delivers 20 Gbps to the server • Helps reduce TCO by consolidating the overall number of NICs, HBAs, cables, and switches because LAN and SAN traffic run over the same adapter card and fabric
Up to 256 dynamic virtual adapters and interfaces	<ul style="list-style-type: none"> • Creates fully functional unique and independent PCIe adapters and interfaces (NICs or HBAs) without requiring Single-Root I/O Virtualization (SR-IOV) support from OSs or hypervisors • Allows these virtual interfaces and adapters to be configured and operated independently, just like physical interfaces and adapters • Creates a highly flexible I/O environment needing only one card for all I/O configurations <p>Note: Cisco UCS VIC 1227 hardware is SR-IOV capable, and you can enable SR-IOV after SR-IOV is broadly supported by the popular operating systems. Please refer to Cisco UCS Manager configuration limits for your specific OS and environment in the configuration guide.</p>
Cisco SingleConnect technology	A single unified network: the same network brings LAN, SAN, and management connectivity to each server
Cisco Data Center VM-FEX technology	<ul style="list-style-type: none"> • Unifies virtual and physical networking in a single infrastructure • Provides virtual machine visibility from the physical network and a consistent network operating model for physical and virtual servers • Enables configurations and policies to follow the virtual machine during virtual machine migration
Centralized management	Enables the card to be centrally managed and configured by Cisco UCS Manager and Cisco Intersight™
Advanced features support	<ul style="list-style-type: none"> • Cisco Adapter FEX • DPDK • Enic and Fnic • Extended RX-ring • iSCSI and iSCSI Boot • Multi RQ • Cisco NetFlow • NetQueue • N-Port ID Virtualization • Receive-Flow Steering • Receive-Segment Coalescing • Receive-Side Scaling • Microsoft SCVMM • SR-IOV • usNIC • Cisco Data Center VM-FEX • VM DirectPath • VMQ

Feature	Benefit
Network architecture	Provides a redundant path to the fabric interconnect using hardware-based fabric failover
More than 600,000 I/O Operations Per Second (IOPS)	Provides high I/O performance for demanding applications
Support for lossless Ethernet	Uses Priority Flow Control (PFC) to enable FCoE as part of the Cisco unified fabric
Broad OS and hypervisor support	Supports customer requirements for Microsoft Windows, Red Hat Enterprise Linux, SUSE Linux, VMware vSphere, and Citrix XenServer

Product specifications

Table 2 lists the specifications for the Cisco UCS VIC 1227.

Table 2. Product specifications

Item	Specifications
Standards	<ul style="list-style-type: none"> • 10-Gbps Ethernet • IEEE 802.3ae • IEEE 802.3x • IEEE 802.1q VLAN • IEEE 802.1p • IEEE 802.1Qaz • IEEE 802.1Qbb • Pre-standard IEEE 802.1BR • Jumbo frames up to 9 KB • Fibre Channel Protocol (FCP) • Small Computer System Interface (SCSI)-FCP • T11 FCoE
Components	Cisco UCS custom Application-Specific Integrated Circuit (ASIC)
Ports	2 x 10-Gbps FCoE SFP+ ports
Connectivity	PCIe 2.0 x8 in mLOM form factor
Performance	10-Gbps line rate per port
Management	Cisco UCS Manager Release 2.2 (3) and higher
Number of interfaces	256 virtual interfaces (approximately 8 are reserved for internal use; other factors such as the OS and hypervisor may limit this number further)

Item	Specifications
Supported media	<ul style="list-style-type: none"> • SFP-10G-USR (Ultra short range, MMF) • SFP-10G-SR (Short range, MMF) • SFP-10G-SR-S (Short range, MMF) • SFP-10G-LR (Long range, SMF) • 10GBASE-CU SFP+ Cable 1 Meter • 10GBASE-CU SFP+ Cable 3 Meter • 10GBASE-CU SFP+ Cable 5 Meter • 10GBASE-CU SFP+ Cable 7 Meter • SFP-10GB-ACU Cable 7 Meter
Physical dimensions	<ul style="list-style-type: none"> • Length = 4.5 in (11.43 cm) • Width = 3.625 in. (9.2075 cm)
Typical power	14 watts (W)

System requirements

The Cisco UCS VIC 1227 is designed for use only on Cisco UCS C-Series Rack Servers. It is supported on Cisco UCS C220 M4 and C240 M4 Rack Servers and on Cisco UCS C3160 Rack Servers, which are dense storage servers. Up to two Cisco UCS VIC 1227 cards are supported on these servers, depending on the slot configuration.

Warranty information

Find warranty information at Cisco.com on the [Product Warranties](#) page.

Cisco Unified Computing Services

Cisco and our industry-leading partners deliver services that accelerate your transition to a unified computing architecture. Cisco Unified Computing Services can help you create an agile infrastructure, accelerate time to value, reduce costs and risks, and maintain availability during deployment and migration. After deployment, our services can help you improve performance, availability, and resiliency as your business needs evolve, and mitigate risk further. For more information, visit <https://www.cisco.com/go/unifiedcomputingservices>.

Why Cisco?

Cisco UCS continues Cisco's long history of innovation in delivering integrated systems for improved business results based on industry standards and using the network as the platform. Recent examples include IP telephony, LAN switching, unified communications, and unified I/O. Cisco began the unified computing phase of our Unified Data Center strategy several years ago by assembling an experienced team from the computing and virtualization industries to augment our own networking and storage access expertise. As a result, Cisco delivered foundational technologies, including the Cisco Nexus® Family, supporting unified fabric and server virtualization. Cisco UCS completes this phase, delivering innovation in architecture, technology, partnerships, and services. Cisco is well-positioned to deliver this innovation by taking a systems approach to computing that unifies network intelligence and scalability with innovative ASICs, integrated management, and standard computing components.

Cisco Capital

Flexible payment solutions to help you achieve your objectives

Cisco Capital makes it easier to get the right technology to achieve your objectives, enable business transformation and help you stay competitive. We can help you reduce the total cost of ownership, conserve capital, and accelerate growth. In more than 100 countries, our flexible payment solutions can help you acquire hardware, software, services and complementary third-party equipment in easy, predictable payments. [Learn more.](#)

For more information

For more information about the Cisco UCS, visit <https://www.cisco.com/en/US/products/ps10265/index.html>.

Americas Headquarters

Cisco Systems, Inc.
San Jose, CA

Asia Pacific Headquarters

Cisco Systems (USA) Pte. Ltd.
Singapore

Europe Headquarters

Cisco Systems International BV Amsterdam,
The Netherlands

Cisco has more than 200 offices worldwide. Addresses, phone numbers, and fax numbers are listed on the Cisco Website at <https://www.cisco.com/go/offices>.

Cisco and the Cisco logo are trademarks or registered trademarks of Cisco and/or its affiliates in the U.S. and other countries. To view a list of Cisco trademarks, go to this URL: <https://www.cisco.com/go/trademarks>. Third-party trademarks mentioned are the property of their respective owners. The use of the word partner does not imply a partnership relationship between Cisco and any other company. (1110R)