

Überprüfung von SPAN und ERSPAN auf Catalyst Switches der Serie 9000

Inhalt

[Einleitung](#)

[Voraussetzungen](#)

[Anforderungen](#)

[Verwendete Komponenten](#)

[SPAN überprüfen](#)

[Netzwerkdiagramm](#)

[SPAN-Konfiguration](#)

[ERSPAN überprüfen](#)

[Netzwerkdiagramm](#)

[ERSPAN-Konfiguration](#)

[Quellgerät](#)

[ERSPAN-Zielgerät](#)

[Relevante Debugs und Traces](#)

[Zugehörige Informationen](#)

Einleitung

In diesem Dokument wird beschrieben, wie Sie SPAN und ERSPAN bei Catalyst Switches der Serie 9000 überprüfen.

Voraussetzungen

Anforderungen

Es gibt keine spezifischen Anforderungen für dieses Dokument.

Verwendete Komponenten

Die Informationen in diesem Dokument basierend auf folgenden Software- und Hardware-Versionen:

- Catalyst 9300 (Cisco IOS®-XE 17.3.5)
- Catalyst 9500 (Cisco IOS®-XE 17.3.5)

Die Informationen in diesem Dokument beziehen sich auf Geräte in einer speziell eingerichteten Testumgebung. Alle Geräte, die in diesem Dokument benutzt wurden, begannen mit einer gelöschten (Nichterfüllungs) Konfiguration. Wenn Ihr Netzwerk in Betrieb ist, stellen Sie sicher, dass Sie die möglichen Auswirkungen aller Befehle verstehen.

Verwandte Produkte

Dieses Dokument kann auch mit folgenden Hardware- und Softwareversionen verwendet werden:

- Catalyst 9200
- Catalyst 9300
- Catalyst 9500
- Catalyst 9400
- Catalyst 9600

SPAN überprüfen

Netzwerkdiagramm

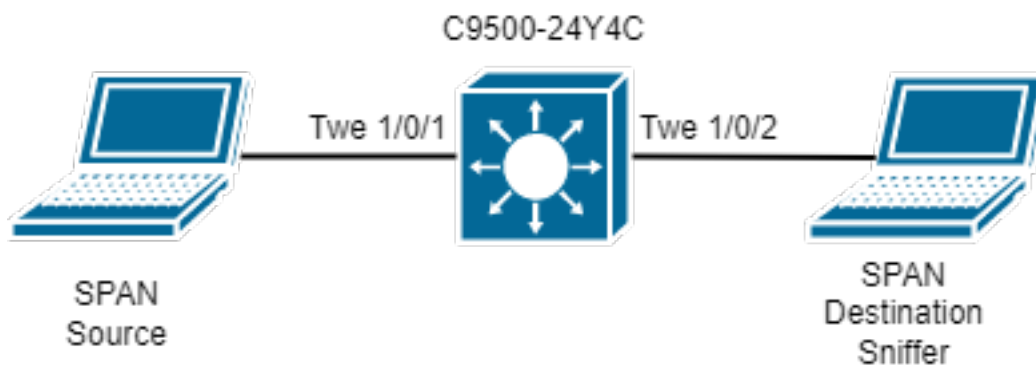

SPAN-Konfiguration

```
monitor session 1 source interface Twe1/0/1
monitor session 1 destination interface Twe1/0/2
```

Überprüfen Sie die SPAN-Softwarekonfiguration. Notieren Sie sich die SPAN-Schnittstellen für Quelle und Ziel und die Richtung der SPAN-Erfassung.

```
C9500-SPAN#show monitor session all
Session 1
-----
Type                : Local Session
Source Ports        :
  Both               : Twe1/0/1
Destination Ports   : Twe1/0/2
Encapsulation       : Native
  Ingress            : Disabled
```

Überprüfen Sie den SPAN-Hardwareeintrag. Verwenden Sie FED-Sitzungs-ID, die für jede SPAN-Konfiguration eindeutig ist. Es können bis zu 8 FED-Sitzungen gleichzeitig konfiguriert werden (von FED-Sitzungen 0 bis 7).

```
C9500-SPAN# show platform software monitor session 1
Span Session 1 (FED Session 0):
  Type:          Local SPAN
  Prev type:     Local SPAN
  Ingress Src Ports: Twe1/0/1    <-- Hardware entry for source interface.
  Egress Src Ports:  Twe1/0/1    <-- Hardware entry for source interface.
  Ingress Local Src Ports: (null)
  Egress Local Src Ports: (null)
```

```

Destination Ports: Twel/0/2 <-- Hardware entry for destination interface.
Ingress Src Vlans:
Egress Src Vlans:
Ingress Up Src Vlans: (null)
Egress Up Src Vlans: (null)
Src Trunk filter Vlans:
RSPAN dst vlan: 0
RSPAN src vlan: 0
RSPAN src vlan sav: 0
Dest port encap = 0x0000
Dest port ingress encap = 0xFFFFFFFFFFFFFFFF
Dest port ingress vlan = 0x0
SrcSess: 1 DstSess: 0 DstPortCfgd: 1 RspnDstCfg: 0 RspnSrcVld: 0
DstCliCfg: 0 DstPrtInit: 1 PsLclCfgd: 0
Flags: 0x00000031 PSPAN
Remote dest port: 0 Dest port group: 0
FSPAN disabled
FSPAN not notified

```

Sammeln Sie ASIC-, Core- und Port-Nummern für die konfigurierten Quell- und Ziel-SPAN-Ports. Die Portnummer ist erforderlich, um zu bestätigen, ob die Quell-SPAN-Schnittstelle richtig programmiert ist und ob der SPAN auf die richtige Ziel-SPAN-Schnittstelle zeigt.

Tipp: Verwenden Sie den richtigen, für die Nomenklatur vorgesehenen Standalone-Device **Show Platform, Software-/Hardware-Feed, Aktiv- oder Stack-Device, Show Platform, Software-/Hardware-Feed Switch <Nummer>**.

```

C9500-SPAN# show platform software fed active ifm mappings
Interface                IF_ID      Inst Asic Core Port SubPort Mac  Cntx LPN  GPN  Type Active
TwentyFiveGigE1/0/1     0x8        1  0  1  20  0    16   4   1   101  NIF  Y
TwentyFiveGigE1/0/2     0x9        1  0  1  21  0    17   5   2   102  NIF  Y

```

Mit dem **IlePortLeSpanBitMapTable** Doppler-Register wird definiert, ob ein Port in Eingangsrichtung (RX) SPAN unterliegt. So bestätigen Sie, dass der konfigurierte Quell-SPAN-Port (ASIC-Port 20) der rechten **FED-Sitzung** (Session 0) zugewiesen wird:

```

C9500-SPAN# show platform hardware fed active fwd-asic register read register-name
IlePortLeSpanBitMapTable-20 asic 0 core 1
For asic 0 core 1

Module 0 - IlePortLeSpanBitMapTable[0][20]

ssbm                      : 0x1 <-- Convert from Hexadecimal to Binary: 0b00000001. Bit 0 is
set.

```

Die SPAN-Sitzungsbitmap ist ein 8-Bit-Register. Jedes Bit entspricht einer FED-Sitzung: Das niederwertigste Bit entspricht der FED-Session 0, das höchstwertige Bit entspricht der FED-Session 7. Es werden also, wie bereits erwähnt, maximal 8 SPAN-Sessions unterstützt.

Wenn eine Schnittstelle als SPAN-Quell-Port für mehrere SPAN-Sitzungen konfiguriert ist, müssen alle FED-Sitzungen im SSBM-Register erscheinen. SSBM mit dem Wert 0x5 (0b00000101) bedeutet beispielsweise, dass die Schnittstelle eine SPAN-Quelle für FED-Sitzung 0 und FED-Sitzung 2 ist.

Ebenso bestimmt das Dopplerregister **ElePortLeSpanBitMapTable** register, ob ein Port in Ausgangs- (TX)-Richtung SPAN unterliegt. Die Analyse entspricht dem **IlePortLeSpanBitMapTable**-Register. So bestätigen Sie, dass der konfigurierte Quell-SPAN-Port (ASIC-Port 20) der rechten **FED-Sitzung** (Session 0) zugewiesen wird:

```
C9500-SPAN# show platform hardware fed active fwd-asic register read register-name
ElePortLeSpanBitMapTable-20 asic 0 core 1
For asic 0 core 1
```

```
Module 0 - ElePortLeSpanBitMapTable[0][20]
```

```
ssbm : 0x1
```

Dadurch wird bestätigt, dass die Quell-SPAN-Schnittstelle der richtigen FED-Sitzung für RX- und TX-Richtung zugeordnet ist.

Mit der **FED-Sitzungs-ID** können wir den/die Zielport(s) für das SPAN im **AqmRepSpanPortMap** Doppler-Register finden. So bestätigen Sie, dass die FED-Sitzung 0 auf den richtigen SPAN-Zielport (ASIC-Port 21) zeigt:

```
C9500-SPAN# show platform hardware fed active fwd-asic register read register-name
AqmRepSpanPortMap-0 asic 0 core 1
For asic 0 core 1
```

```
Module 0 - AqmRepSpanPortMap[0][0]
```

```
cpuQueueNum : 0x0
cpuSpanValid : 0x0
indirectApPortMap : 0x0
portMap0 : 0x200000 <-- Convert from Hexadecimal to Binary:
0b00100000000000000000000000000000. Bit 21 is set.
rcpPortMap : 0x0
spanCtiLo : 0x0
```

Dies bestätigt, dass die mit SPAN erfassten Pakete repliziert von der Schnittstelle Tw1/0/2 (ASIC-Port 21) angezeigt werden müssen. Wenn mehr SPAN-Ziel-Ports konfiguriert sind, werden diese im Register "AqmRepSpanPortMap" angezeigt.

ERSPAN überprüfen

Netzwerkdiagramm

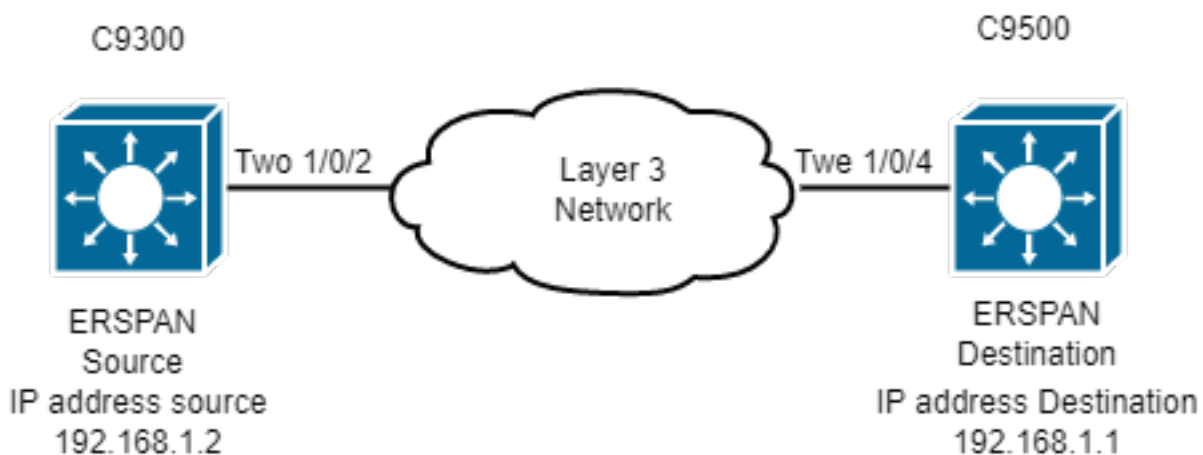

Anmerkung: Catalyst C9200 unterstützt kein ERSPAN.

Anmerkung: DNA-Advantage-Lizenz erforderlich.

ERSPAN-Konfiguration

Source ESRPAN Device

```
C9300-ERSPAN# show run | section monitor
monitor session 1 type erspan-source
  source vlan 10
  destination
    erspan-id 3 <-- ERSpan id must be identical on source and destination.
    ip address 192.168.1.1 <-- GRE tunnel destination IP (IP addr configured on ERSpan
destination switch).
    origin ip address 192.168.1.2 <-- GRE tunnel source IP (IP addr configured on ERSpan source
switch).
```

```
C9300-ERSPAN# show ip interface brief | exclude unassigned
Interface IP-Address OK? Method Status Protocol
<snip>
Loopback0 192.168.1.2 YES NVRAM up up
```

Destination ERSpan Device

```
C9500-ERSPAN# show run | section monitor
monitor session 1 type erspan-destination
destination interface Twel/0/3
source
erspan-id 3 <-- ERSpan id must be identical on source and destination.
ip address 192.168.1.1 <-- GRE tunnel destination IP (IP addr configured on ERSpan destination
switch).
```

```
C9500-ERSPAN# show ip interface brief | exclude unassigned
Interface IP-Address OK? Method Status Protocol
<snip>
Loopback0 192.168.1.1 YES NVRAM up up
```

Quellgerät

Überprüfen der Erreichbarkeit zwischen Ursprungs- und Ziel-IP-Adresse

```
C9300-ERSPAN#ping 192.168.1.1 source 192.168.1.2
Type escape sequence to abort.
Sending 5, 100-byte ICMP Echos to 192.168.1.1, timeout is 2 seconds:
Packet sent with a source address of 192.168.1.2
!!!!
Success rate is 100 percent (5/5), round-trip min/avg/max = 1/1/2 ms
```

Cisco IOS Software-Programmierung

Überprüfen Sie in der Cisco IOS-Software den Eintrag für die ERSpan-Sitzung.

```
C9300-ERSPAN#show monitor session 1
Session 1
-----
Type : ERSpan Source Session
Status : Admin Enabled
```

```
Source VLANs          :
  Both                : 10
Destination IP Address : 192.168.1.1
Destination ERSPAN ID  : 3
Origin IP Address      : 192.168.1.2
```

SHIM-Programmierung

Überprüfen Sie, welche Software an die Programmhardware sendet (SHIM-Objekt).

```
C9300-ERSPAN#show platform software monitor session 1
Span Session 1 (FED Session 0):
  Type:          ERSPAN Source
  Prev type:     Unknown
  Ingress Src Ports:
  Egress Src Ports:
  Ingress Local Src Ports: (null)
  Egress Local Src Ports: (null)
  Destination Ports:
  Ingress Src Vlan: 10      <-- Replicate Traffic.
  Egress Src Vlan: 10      <-- Replicate Traffic.
  Ingress Up Src Vlan: 10
  Egress Up Src Vlan: 10
  Src Trunk filter Vlan:
  RSPAN dst vlan: 0
  RSPAN src vlan: 0
  RSPAN src vlan sav: 0
  Dest port encap = 0x0000
  Dest port ingress encap = 0x0000
  Dest port ingress vlan = 0x0
  SrcSess: 1  DstPortCfgd: 0  RspnDstCfg: 0  RspnSrcVld: 0  <-- Monitor session number.
  DstCliCfg: 0  DstPrtInit: 0  PsLclCfgd: 0
  Flags: 0x00000002 VSPAN
  Remote dest port: 0  Dest port group: 0
  FSPAN disabled
  FSPAN not notified
  ERSPAN Id      : 3          <-- Value match with the software setting.
  ERSPAN Org Ip: 192.168.1.2 <-- Value match with the software setting.
  ERSPAN Dst Ip: 192.168.1.1 <-- Value match with the software setting.
  ERSPAN Ip Ttl: 255
  ERSPAN State  : Enabled
  ERSPAN Tun id: 77
```

Weiterleitungs-Manager-Routingprozessor

Überprüfen Sie, welche Software an die Programmhardware (FMAN RP Layer) sendet.

```
C9300-ERSPAN#show platform software swspan switch active R0 source
Showing SPAN source table summary info
```

Sess-id	IF-type	IF-id	Sess-type	Dir
0	VLAN	10	ERSPAN SRC	Ingress
0	VLAN	10	ERSPAN SRC	Egress

```
C9300-ERSPAN#show platform software swspan switch active R0 source sess-id 0
Showing SPAN source detail info
Session ID : 0 Intf Type : VLAN Vlan id : 10 <-- Vlan entry
PD Sess ID : 0
Session Type : ERSPAN SRC
```

Direction : Ingress
Filter Enabled : No
ACL Configured : No
ERSPAN Enable : Yes

Session ID : 0
Intf Type : VLAN
Vlan id : 10 <-- Match with the Vlan/Interface SPAN.
PD Sess ID : 0
Session Type : ERSPAN SRC
Direction : Egress
Filter Enabled : No
ACL Configured : No
ERSPAN Enable : Yes

Forward Manager Forwarding-Prozessor

Überprüfen Sie, welche Software an die Programmhardware (FMAN FP Layer) sendet.

C9300-ERSPAN#**show platform software swspan switch active F0 source**
Showing SPAN source table summary info

Sess-id	IF-type	IF-id	Sess-type	Dir
0	VLAN	10	ERSPAN SRC	Ingress
0	VLAN	10	ERSPAN SRC	Egress

C9300-ERSPAN#**show platform software swspan switch active F0 source sess-id 0**
Showing SPAN source detail info

Session ID : 0
Intf Type : VLAN
Vlan id : 10
PD Sess ID : 0
Session Type : ERSPAN SRC <-- Source Interface.
Direction : Ingress
Filter Enabled : No
ACL Configured : No
AOM Object id : 519
AOM Object Status : Done
Parent AOM object Id : 30
Parent AOM object Status : Done

Session ID : 0
Intf Type : VLAN
Vlan id : 10
PD Sess ID : 0
Session Type : ERSPAN SRC <-- Source Interface.
Direction : Egress
Filter Enabled : No
ACL Configured : No
AOM Object id : 520
AOM Object Status : Done
Parent AOM object Id : 30
Parent AOM object Status : Done

C9300-ERSPAN#**show platform software swspan switch active F0 counters** <-- Check for any error counters that increment on PI/PD/HW
Dump Switch SPAN FP operation counters <-- Operational Counters.

Source SPAN Config Counters

PI: Create 2 (err 0), Modify 0 (err 0), Delete 0 (err 0) <-- PI = platform independent (Software/IOS).

PD: Create 2 (err 0), Modify 0 (err 0), Delete 0 (err 0) <-- PD = platform dependent (SHIM/FMAN/FED).

HW: Create 2 (err 0), Modify 0 (err 0), Delete 0 (err 0) <-- HW = hardware (FED/ASIC).

Destination SPAN Config Counters

PI: Create 1 (err 0), Modify 0 (err 0), Delete 0 (err 0)

PD: Create 1 (err 0), Modify 0 (err 0), Delete 0 (err 0)

HW: Create 1 (err 0), Modify 0 (err 0), Delete 0 (err 0)

Filter SPAN Config Counters

PI: Create 0 (err 0), Modify 0 (err 0), Delete 0 (err 0)

PD: Create 0 (err 0), Modify 0 (err 0), Delete 0 (err 0)

HW: Create 0 (err 0), Modify 0 (err 0), Delete 0 (err 0)

Forwarding-Engine-Treiber

Überprüfen Sie die Ebene, die den ASIC (FED) programmiert.

```
C9300-ERSPAN#show platform software fed switch active monitor 0
```

```
Session 0
```

```
-----
```

```
Session Type      : ERSpan Source Session
Source Ports      : RX: None TX: None
Destination Ports : None
Source VLANs     : VLAN-10
Destination VLANs : VLAN-10
Source RSPAN VLAN : 0
DST RSPAN VLAN   : 0
Encap             : Native
Ingress Forwarding : Disabled
Filter VLANs     : None
ERSPAN Enable    : 1          <-- 1 = On/Completed.
ERSPAN Hw Programmed : 1      <-- 1 = On/Completed.
ERSPAN Mandatory Cfg : 1      <-- 1 = On/Completed.
ERSPAN Id        : 3
Gre Prot         : 88be
MTU              : 9000
Ip Tos           : 0
Ip Ttl          : 255
Cos              : 0
Vrf Id          : 0
Dst Ip           : 192.168.1.1
```

```
Org Ip : 192.168.1.2
```

```
Dst Ipv6 : ::
```

```
Org Ipv6 : ::
```

```
SGT count : 0
```

```
SGT Tag(s) :
```

Überprüfen der Hardware-Tunnelprogrammierung

```
C9300-ERSPAN#show platform software fed switch active ifm interfaces tunnel
```

```
Interface          IF_ID          State
-----
```

Tunnel1000000000 0x00000035 READY <-- 0x35 in Hex is 53 in Decimal (tunnel number 53).

C9300-ERSPAN#show platform software fed switch active ifm if-id 0x35 <-- Hardware tunnel number 0x35.

Interface IF_ID : 0x0000000000000035
Interface Name : Tunnel1000000000
Interface Block Pointer : 0x55d0ff5b6c98
Interface Block State : READY
Interface State : Enabled
Interface Status : ADD
Interface Ref-Cnt : 4
Interface Type : TUNNEL
Unit : 0
SNMP IF Index : 0
Encap L3If LE Handle : 0x7f00e0a50a28 <-- Hardware handle info (used to check final Hardware program state).
Decap L3If LE Handle : 0x7f00e0a50bd8 <-- Hardware handle info (used to check final Hardware program state).
Tunnel Mode : 0 [gre] <-- Tunnel Protocol Enable.
Tunnel Sub-mode: 0 [none]
Hw Support : Yes
Tunnel Vrf : 0
IPv4 MTU : 0
IPv6 MTU : 0
IPv4 VRF ID : 0
IPv6 VRF ID : 0
Protocol flags : 0x0001 [ipv4]
Misc flags : 0x0000 [None]
ICMPv4 flags : 0x03 [unreachable redirect]
ICMPv6 flags : 0x03 [unreachable redirect]

Port Information
Handle [0xcf000051]
Type [L3-Tunnel]
Identifier [0x35]
Unit [53]
Port Logical Tunnel Subblock
Encap-L3ifle.....[0x7f00e0a50a28] <-- Same number as previous highlighted output.
Decap-L3ifle.....[0x7f00e0a50bd8] <-- Same number as previous highlighted output.
decap-portle.....[0x0]
RI-decap.....[0x7f00e0a5a1a8]
SI-decap.....[0x7f00e0a5a678]
Decap-Tcam_handle..[0x7f00e0a5a9a8]
Tunnel_capability..[0x3]
Encap-RCP-PMAP.....[0x0]
GPN.....[0]

C9300-ERSPAN#show platform software fed switch active ifm mappings l3if-le | include L3IF|Tunnel

L3IF_LE	Interface	IF_ID	Type
0x00007f00e0a50a28	Tunnel1000000000	0x00000035	ENCAP_L3_LE <--
L3IF + IF_ID (ENCAP) match here.			
0x00007f00e0a50bd8	Tunnel1000000000	0x00000035	DECAP_L3_LE <--
L3IF + IF_ID (DECAP) match here.			

Encapsulation LE

C9300-ERSPAN#show platform hardware fed switch active fwd-asic abstraction print-resource-handle 0x00007f00e0a50a28 0 <-- ENCAP.
Handle:0x7f00e0a50a28 Res-Type:ASIC_RSC_L3IF_LE Res-Switch-Num:255 Asic-Num:255 Feature-ID:AL_FID_IFM Lkp-ftr-id:LKP_FEAT_INVALID ref_count:1
priv_ri/priv_si Handle: (nil)Hardware Indices/Handles: **index0:0x27** mtu_index/l3u_ri_index0:0x5

```
sm handle [ASIC 0]: 0x7f00e0a56d08 index1:0x27 mtu_index/l3u_ri_index1:0x5
```

```
=====
```

Decapsulation LE

```
C9300-ERSPAN#show platform hardware fed switch active fwd-asic abstraction print-resource-handle  
0x00007f00e0a50a28 0 <-- DECAP.
```

```
Handle:0x7f00e0a50bd8 Res-Type:ASIC_RSC_L3IF_LE Res-Switch-Num:255 Asic-Num:255 Feature-  
ID:AL_FID_IFM Lkp-ftr-id:LKP_FEAT_INVALID ref_count:1
```

```
priv_ri/priv_si Handle: (nil)Hardware Indices/Handles: index0:0x28 mtu_index/l3u_ri_index0:0x0
```

```
sm handle [ASIC 0]: 0x7f00e0a559c8 index1:0x28 mtu_index/l3u_ri_index1:0x0
```

```
=====
```

Führen Sie Embedded Packet Capture am Ausgangsport zum Ziel-Switch aus. Es kann ein Filter angewendet werden. Verwenden Sie die Quell- und Ziel-IP-Adresse des GRE-Tunnels (Das Paket ist ein gekapseltes Paket).

```
Frame 1: 110 bytes on wire (880 bits), 110 bytes captured (880 bits) on interface 0
```

```
<snip>
```

```
Internet Protocol Version 4, Src: 192.168.1.2, Dst: 192.168.1.1 <-- ERSpan IP HEADER.
```

```
0100 .... = Version: 4
```

```
.... 0101 = Header Length: 20 bytes (5)
```

```
Differentiated Services Field: 0x00 (DSCP: CS0, ECN: Not-ECT)
```

```
0000 00.. = Differentiated Services Codepoint: Default (0)
```

```
.... ..00 = Explicit Congestion Notification: Not ECN-Capable Transport (0)
```

```
Total Length: 96
```

```
Identification: 0x1018 (4120)
```

```
Flags: 0x00
```

```
0... .... = Reserved bit: Not set
```

```
.0.. .... = Don't fragment: Not set
```

```
..0. .... = More fragments: Not set
```

```
Fragment offset: 0
```

```
Time to live: 255
```

```
Protocol: Generic Routing Encapsulation (47) <-- GRE tunnel encapsulation.
```

```
Header checksum: 0x9c56 [validation disabled]
```

```
[Good: False]
```

```
[Bad: False]
```

```
Source: 192.168.1.2
```

```
<-- Source GRE IP tunnel.
```

```
Destination: 192.168.1.1
```

```
<-- Destination GRE IP tunnel.
```

```
Generic Routing Encapsulation (ERSPAN)
```

```
Flags and Version: 0x1000
```

```
0... .... = Checksum Bit: No
```

```
.0.. .... = Routing Bit: No
```

```
..0. .... = Key Bit: No
```

```
...1 .... = Sequence Number Bit: Yes
```

```
.... 0... = Strict Source Route Bit: No
```

```
.... .000 = Recursion control: 0
```

```
.... .... 0000 0... = Flags (Reserved): 0
```

```
.... .... .... .000 = Version: GRE (0)
```

```
Protocol Type: ERSpan (0x88be)
```

```
<--ERSPAN enable.
```

```
Sequence Number: 0
```

Encapsulated Remote Switch Packet Analysis

```
0001 .... = Version: Type II (1)
```

```
.... 0000 0001 1000 = Vlan: 10
```

```
000. .... = Priority: 0
```

```
...1 .... = Unknown2: 1
```

```
.... 1... = Direction: Outgoing (1)
```

```
.... .0.. = Truncated: Not truncated (0)
```

```
.... ..00 0000 0011 = SpanID: 3 <--ERSPAN ID.
```

```
Unknown7: 00000002
```

```
Ethernet II, Src: Xerox_00:02:00 (00:00:08:00:02:00), Dst: Cisco_eb:90:68 (00:9e:1e:eb:90:68)
```

```
<snip>
```

```
(Internal data packet comes here, output truncated)
```

ERSPAN-Zielgerät

Cisco IOS Softwareprogrammierung

```
C9500-ERSPAN#show monitor session 1
```

```
Session 1
```

```
-----
```

```
Type                : ERSPAN Destination Session
Status              : Admin Enabled
Destination Ports   : Twel/0/3
Source IP Address   : 192.168.1.1
Source ERSPAN ID    : 3
```

SHIM-Programmierung

Überprüfen Sie, welche Software an die Programmhardware sendet (SHIM-Objekt).

```
C9500-ERSPAN#show platform software monitor session 1
```

```
Span Session 1 (FED Session 0):
```

```
Type:          ERSPAN Destination
Prev type:     Unknown
Ingress Src Ports:
Egress Src Ports:
Ingress Local Src Ports: (null)
Egress Local Src Ports: (null)
Destination Ports: Twel/0/3
Ingress Src Vlans:
Egress Src Vlans:
Ingress Up Src Vlans: (null)
Egress Up Src Vlans: (null)
Src Trunk filter Vlans:
RSPAN dst vlan: 0
RSPAN src vlan: 0
RSPAN src vlan sav: 0
Dest port encap = 0x0004
Dest port ingress encap = 0x0000
Dest port ingress vlan = 0x0
SrcSess: 0  DstSess: 1  DstPortCfgd: 1  RspnDstCfg: 0  RspnSrcVld: 0
DstCliCfg: 0  DstPrtInit: 1  PsLclCfgd: 0
Flags: 0x00000000
Remote dest port: 0  Dest port group: 0
FSPAN disabled
FSPAN not notified
ERSPAN Id      : 3
ERSPAN Dst Ip: 192.168.1.1
ERSPAN Vrf     : 0
```

Forward Manager Forwarding-Prozessor

Überprüfen Sie, welche Software an die Programmhardware (FMAN FP Layer) sendet.

```
C9500-ERSPAN#show platform software swspan switch active r0 destination
```

```
Showing SPAN destination table summary info Sess-id IF-type IF-id Sess-type -----
```

```
----- 0 PORT 11 Local <-- IF-if 0xb maps to Twel/0/3 (Check under 'show
platform software fed active ifm mapping').
```

```
0 ERSPAN ERSPAN DST
```

```
C9500-ERSPAN#show platform software swspan R0 destination sess-id 0
Showing SPAN destination detail info
```

```
Session ID : 0
Intf Type : PORT
Port dpidx :11 <--Match with IF-id
PD Sess Id : 0
Session Type : Local <-- Type of monitor session
Ingress Fwd : No
Ingress Encap : Disabled
Ingress Vlan : 0
Encap Value : Replicate
RSPAN Vlan : 0
```

```
Session ID : 0
Intf Type : ERSPAN
Vlan id :
PD Sess Id : 0
Session Type : ERSPAN DST
ERSPAN Id : 3
ERSPAN Dst Ip: 192.168.1.1
ERSPAN Src Ip: 0.0.0.0
GRE Prot : 35006
MTU : 0
IP Tos : 0
IP Ttl : 255
Cos : 0
Vrf Id : 0
Tunnel Ifid: 38 <-- 38 in Decimal is 0x26 in Hex which is the IF_ID of Tunnel1
ERSPAN En : TDL_TRUE
```

Forward Manager Forwarding-Prozessor

Überprüfen Sie, welche Software an die Programmhardware (FMAN FP Layer) sendet.

```
C9500-ERSPAN#show platform software swspan switch active F0 counters <-- (check for any error
counters on PI/PD/HW).
```

```
Dump Switch SPAN FP operation counters
```

```
Source SPAN Config Counters
```

```
PI: Create 0 (err 0), Modify 0 (err 0), Delete 0 (err 0) <-- PI = platform independent
(Software/IOS).
PD: Create 0 (err 0), Modify 0 (err 0), Delete 0 (err 0) <-- PD = platform dependent
(SHIM/FMAN/FED).
HW: Create 0 (err 0), Modify 0 (err 0), Delete 0 (err 0) <-- HW = hardware (FED/ASIC).
```

```
Destination SPAN Config Counters
```

```
PI: Create 10 (err 0), Modify 6 (err 0), Delete 4 (err 0)
PD: Create 4 (err 0), Modify 0 (err 0), Delete 2 (err 0)
HW: Create 4 (err 0), Modify 0 (err 0), Delete 2 (err 0)
```

```
Filter SPAN Config Counters
```

```
PI: Create 0 (err 0), Modify 0 (err 0), Delete 0 (err 0)
PD: Create 0 (err 0), Modify 0 (err 0), Delete 0 (err 0)
HW: Create 0 (err 0), Modify 0 (err 0), Delete 0 (err 0)
```

```
C9500-ERSPAN#show platform software swspan switch active F0 destination
```

Showing SPAN destination table summary info

Sess-id	IF-type	IF-id	Sess-type
0	PORT	11	Local
0	VLAN	0	ERSPAN DST

Forwarding-Engine-Treiber

Überprüfen Sie die Ebene, die den ASIC (FED) programmiert.

```
C9500-ERSPAN#show platform software fed switch active monitor 0
```

```
Session 0
```

```
-----  
Session Type           : ERSPAN Destination Session  
Source Ports : RX: None TX: Tunnel1000000000 Destination Ports : TwentyFiveGigE1/0/3  
Source VLANs          : None  
Destination VLANs     : None  
Source RSPAN VLAN     : 0  
DST RSPAN VLAN        : 0  
Encap                  : Replicate  
Ingress Forwarding    : Disabled  
Filter VLANs          : None  
ERSPAN Enable         : 1  
ERSPAN Hw Programmed : 1  
ERSPAN Mandatory Cfg  : 1  
ERSPAN Id            : 3  
Ip Tos                 : 0 (DSCP:0)  
Ip Ttl                 : 0  
Cos                    : 0  
Vrf Id                 : 0  
Tunnel IfId          : 38 <-- 38 in Decicmal is 0x26 in Hex which is the IF_ID  
of Tunnel1  
Dst Ip                : 192.168.1.1  
Org Ip                 : 0.0.0.0  
SGT count              : 0  
SGT Tag(s)             :
```

Überprüfen der Hardware-Tunnelprogrammierung

```
C9500-ERSPAN#show platform software fed switch active ifm interfaces tunnel
```

```
Interface IF_ID State
```

```
-----  
Tunnel1000000000 0x00000026 READY
```

```
C9500-ERSPAN#show platform software fed switch active ifm if-id 0x00000026
```

```
Interface IF_ID : 0x00000000000000026  
Interface Name : Tunnel1000000000  
Interface Block Pointer : 0x7f2cd48e9958  
Interface Block State : READY  
Interface State : Enabled  
Interface Status : ADD  
Interface Ref-Cnt : 5  
Interface Type : TUNNEL  
Unit : 0 SNMP IF Index : 0 Encap L3If LE Handle : 0x7f2cd4904e08 <-- Hardware handle info  
(used to check final Hardware program state).  
Decap L3If LE Handle : 0x7f2cd48dabc8 <-- Hardware handle info (used to check final Hardware  
program state).
```

```

Tunnel Mode      : 0 [gre]                <-- Tunnel Protocol Enable.
Hw Support       : Yes
Tunnel Vrf       : 0
IPv4 MTU         : 0
IPv6 MTU         : 0
IPv4 VRF ID      : 0
IPv6 VRF ID      : 0
Protocol flags   : 0x0001 [ ipv4 ]
Misc flags       : 0x0000 [ None ]
ICMPv4 flags     : 0x03 [ unreachable redirect ]
ICMPv6 flags     : 0x03 [ unreachable redirect ]

```

Port Information

```

Handle ..... [0xd4000043]
Type ..... [L3-Tunnel] Identifier ..... [0x26] Unit ..... [38] Port Logical
Tunnel Subblock Encap-L3if1e.....[0x7f2cd4904e08] <-- Same number as previous highlighted
output.
Decap-L3if1e.....[0x7f2cd48dabc8] <-- Same number as previous highlighted output.
decap-portle.....[0x0]
RI-decap.....[0x7f2cd49615d8] <-- Same number as previous highlighted output.
SI-decap.....[0x7f2cd4958dd8] <-- Same number as previous highlighted output.
Decap-Tcam_handle..[0x7f2cd46eee08] <-- Same number as previous highlighted output.
Tunnel_capability..[0x3]
Encap-RCP-PMAP.....[0x0]
GPN.....[0]
<snip>

```

```

C9500-ERSPAN#show platform software fed switch active ifm mappings l3if-1e | include L3IF|Tunnel
L3IF_LE                Interface                IF_ID                Type
0x00007f2cd48dabc8     Tunnel1000000000    0x000000026         DECAP_L3_LE
<-- L3IF + IF_ID (DECAP) match here.
0x00007f2cd4904e08     Tunnel1000000000    0x000000026         ENCAP_L3_LE
<-- L3IF + IF_ID (ENCAP) match here.

```

Encapsulation LE

```

C9500-ERSPAN#show platform hardware fed switch active fwd-asic abstraction print-resource-handle
0x7f2cd4904e08 0 <--ENCAP
Handle:0x7f2cd4904e08 Res-Type:ASIC_RSC_L3IF_LE Res-Switch-Num:255 Asic-Num:255 Feature-
ID:AL_FID_IFM Lkp-ftr-id:LKP_FEAT_INVALID ref_count:1
priv_ri/priv_si Handle: (nil)Hardware Indices/Handles: index0:0x27 mtu_index/l3u_ri_index0:0x2
sm handle [ASIC 0]: 0x7f2cd46ece38 index1:0x27 mtu_index/l3u_ri_index1:0x4

```

=====

Decapsulation LE

```

C9500-ERSPAN#show platform hardware fed switch active fwd-asic abstraction print-resource-handle
0x7f2cd48dabc8 0 <--DECAP
Handle:0x7f2cd48dabc8 Res-Type:ASIC_RSC_L3IF_LE Res-Switch-Num:255 Asic-Num:255 Feature-
ID:AL_FID_IFM Lkp-ftr-id:LKP_FEAT_INVALID ref_count:1
priv_ri/priv_si Handle: (nil)Hardware Indices/Handles: index0:0x28 mtu_index/l3u_ri_index0:0x0
sm handle [ASIC 0]: 0x7f2cd46d91c8 index1:0x28 mtu_index/l3u_ri_index1:0x0

```

Rewrite Index (decapsulation)

```

C9500-ERSPAN#show platform hardware fed switch active fwd-asic abstraction print-resource-handle
0x7f2cd49615d8 1 <-- RI-decap
Handle:0x7f2cd49615d8 Res-Type:ASIC_RSC_RI Res-Switch-Num:255 Asic-Num:255 Feature-ID:AL_FID_GRE
Lkp-ftr-id:LKP_FEAT_INVALID ref_count:1
priv_ri/priv_si Handle: 0x7f2cd48daf28Hardware Indices/Handles: index0:0x16
mtu_index/l3u_ri_index0:0x0 index1:0x16 mtu_index/l3u_ri_index1:0x0

```

Features sharing this resource:107 (1)]
Cookie length: 56
00 00 00 00 00 00 00 00 28 00 00 00 00 00 00 00 00 00 00 00 00 00 00 00 00 00 00 00 01 6b 33 00
00 00

Detailed Resource Information (ASIC# 0) -----
Rewrite Data Table Entry, ASIC#:0 RI:22 Rewrite_type:AL_RRM_REWRITE_IPV4_ERSPAN2_DECAP(61)
Mapped_rii:TUNNEL_IPv4Erspan_DECAP(83) **L3IF LE Index: 40** <-- 64 in Decimal is 0x40
in Hex which matches Decap LE index seen above

Detailed Resource Information (ASIC# 1)

Rewrite Data Table Entry,
ASIC#:1 RI:22 Rewrite_type:AL_RRM_REWRITE_IPV4_ERSPAN2_DECAP(61)
Mapped_rii:TUNNEL_IPv4Erspan_DECAP(83)

L3IF LE Index: 40 =====

Station Index (decapsulation)

C9500-ERSPAN#show platform hardware fed switch active fwd-asic abstraction print-resource-handle
0x7f2cd4958dd8 1 <-- SI-decap

Handle:0x7f2cd4958dd8 Res-Type:ASIC_RSC_SI Res-Switch-Num:255 Asic-Num:255 Feature-ID:AL_FID_GRE
Lkp-ftr-id:LKP_FEAT_INVALID ref_count:1
priv_ri/priv_si Handle: 0x7f2cd49615d8Hardware Indices/Handles: index0:0xae
mtu_index/l3u_ri_index0:0x0 index1:0xae mtu_index/l3u_ri_index1:0x0

Features sharing this resource:107 (1)]
Cookie length: 56
00 00 00 00 00 00 00 00 28 00 00 00 00 00 00 00 00 00 00 00 00 00 00 00 00 00 00 00 01 6b 36 00
00 00

Detailed Resource Information (ASIC# 0) ----- Station Index (SI) [0xae]

RI = 0x16 DI = 0x5012 stationTableGenericLabel = 0 stationFdConstructionLabel = 0x7
lookupSkipIdIndex = 0x15 rcpServiceId = 0 dejaVuPreCheckEn = 0 Replication Bitmap: LD Detailed Resource Information (ASIC# 1) ----- Station Index (SI) [0xae]

RI = 0x16 DI = 0x5012 stationTableGenericLabel = 0 stationFdConstructionLabel = 0x7
lookupSkipIdIndex = 0x15 rcpServiceId = 0 dejaVuPreCheckEn = 0 Replication Bitmap: CD
=====

Tunnel Decap (TCAM)

C9500-ERSPAN#show platform hardware fed switch active fwd-asic abstraction print-resource-handle
0x7f2cd46eee08 1 <-- Decap-Tcam_handle.

Handle:0x7f2cd46eee08 Res-Type:ASIC_RSC_HASH_TCAM Res-Switch-Num:0 Asic-Num:255 Feature-ID:AL_FID_GRE
Lkp-ftr-id:LKP_FEAT_TT_IPV4_GRE ref_count:1
priv_ri/priv_si Handle: (nil)Hardware Indices/Handles: handle [ASIC: 0]: 0x7f2cd48db018
Detailed Resource Information (ASIC# 0) ----- Number of HTM

Entries: 3 **Entry 0: (handle 0x7f2cd48db018)**

Labels	Port	Vlan	L3If	Group
M:	0000	0000	0000	0000
V:	0000	0000	0000	0000

M: ffffffff 00000000 00000000 000003ff 00000000 00000100 01000000 00000fff
3f000000 V: **c0a80101** 00000000 00000000 00000003 00000000 00000100 01000000 00000000 <--
c0a80101 in Hex maps to 192.168.1.1
00000000

GREv4 Dst Src Key C S R D E F VRF Fl L3P GreP Misc RCPSVCId
M: ffffffff 00000000 00000000 0 0 0 0 0 1 000 0 00 0000 00 3f <-- F=1

Forwarding

V: **c0a80101** 00000000 00000000 0 0 0 0 0 1 000 0 00 0000 00 00
Action: 00000100 06000000 00000000 00000000 00000000 00000000 000000ad 00000000

00000000 00000000
RL2 RL3 ACF SPK CLPC LKV PRI STL LPC ADC LKI SI

0 1 0 0 0 0 6 0 0 0 0 ad <-- Hexadecimal
value for Station Index.

Start/Skip Word: 0x00000003
Start Feature, Terminate

Entry 1: (handle 0x7f2cd495c3f8)

Labels Port Vlan L3If Group
M: 0000 0000 0000 0000
V: 0000 0000 0000 0000

M: ffffffff 00000000 00000000 000003ff 00000000 00000100 00000000 000a0000
3f000000
V: c0a80101 00000000 00000000 00000003 00000000 00000100 00000000 00080000
00000000

GREv4 Dst Src Key C S R D E F VRF Fl L3P GreP Misc RCPSVCId
M: ffffffff 00000000 00000000 0 0 0 0 0 0 000 a 00 0000 00 3f
V: c0a80101 00000000 00000000 0 0 0 0 0 0 000 8 00 0000 00 00
Action: 00000100 06000000 00000000 00000000 00000000 00000000 000000ad 00000000
00000000 00000000
RL2 RL3 ACF SPK CLPC LKV PRI STL LPC ADC LKI SI

0 1 0 0 0 0 6 0 0 0 0 ad
Start/Skip Word: 0x00000000
No Start, Terminate

Entry 2: (handle 0x7f2cd46ef568)

Labels Port Vlan L3If Group
M: 0000 0000 0000 0000
V: 0000 0000 0000 0000

M: ffffffff 00000000 00000000 000003ff 00000000 00000100 00000000 00020fff
00000000
V: c0a80101 00000000 00000000 00000003 00000000 00000100 00000000 00000000
00000000

GREv4 Dst Src Key C S R D E F VRF Fl L3P GreP Misc RCPSVCId
M: ffffffff 00000000 00000000 0 0 0 0 0 0 000 2 00 0000 00 00
V: c0a80101 00000000 00000000 0 0 0 0 0 0 000 0 00 0000 00 00
Action: 00000100 06000000 00000000 00000000 00000000 00000000 000000ae 00000000
00000000 00000000
RL2 RL3 ACF SPK CLPC LKV PRI STL LPC ADC LKI SI

0 1 0 0 0 0 6 0 0 0 0 ae <-- Hexadecimal
value for Station Index.

Start/Skip Word: 0x00000000
No Start, Terminate

=====

C9500-ERSPAN#show platform hardware fed switch active fwd-asic resource asic 0 station-index
range 0xab 0xab

ASIC#0:
Station Index (SI) [0xad]
RI = 0x14
DI = 0x505a <-- Destination Index
stationTableGenericLabel = 0
stationFdConstructionLabel = 0x7
lookupSkipIdIndex = 0x15

```
rcpServiceId = 0xd
dejaVuPreCheckEn = 0
Replication Bitmap: LD
```

```
C9500-ERSPAN#show platform hardware fed switch active fwd-asic resource asic 0 station-index
range 0xae 0xae
```

```
Station Index (SI) [0xae]
RI = 0x16
DI = 0x5012 <-- Destination Index
stationTableGenericLabel = 0
stationFdConstructionLabel = 0x7
lookupSkipIdIndex = 0x15
rcpServiceId = 0
dejaVuPreCheckEn = 0
Replication Bitmap: LD
```

```
C9500-ERSPAN#show platform hardware fed switch active fwd-asic resource asic 0 destination-index
range 0x505a 0x505a
```

```
Destination index = 0x505a DI_RCP_PORT2
pmap = 0x00000000 0x00000000
cmi = 0x0
rcp_pmap = 0x2
```

```
al_rsc_cmi
CPU Map Index (CMI) [0]
ctiLo0 = 0
ctiLo1 = 0
ctiLo2 = 0
cpuQNum0 = 0
cpuQNum1 = 0
cpuQNum2 = 0
npuIndex = 0
stripSeg = 0
copySeg = 0
```

```
C9500-ERSPAN#show platform hardware fed switch active fwd-asic resource asic 0 destination-index
range 0x5012 0x5012
```

```
ASIC#0:
Destination Index (DI) [0x5012]
portMap = 0x00000000 00000000
cmil = 0
rcpPortMap = 0x1
```

```
CPU Map Index (CMI) [0]
ctiLo0 = 0
ctiLo1 = 0
ctiLo2 = 0
cpuQNum0 = 0
cpuQNum1 = 0
cpuQNum2 = 0
npuIndex = 0
stripSeg = 0
copySeg = 0
```

Relevante Debugs und Traces

Cisco IOS XE

```
debug monitor all
debug platform monitor
```

FMAN-RP

```
set platform software trace forwarding-manager switch <> R0 switch-span verbose
show platform software trace message forwarding-manager switch <> R0
```

FMAN-FP

```
set platform software trace forwarding-manager switch <> F0 switch-span verbose
show platform software trace message forwarding-manager switch <> F0
```

FED

```
set platform software trace fed switch <> swspan verbose
set platform software trace fed switch <> asic_spn verbose
set platform software trace fed switch <> acl verbose (Useful when ip/ipv6 filter is
configured)
show platform software trace message fed switch <>
```

Zugehörige Informationen

- [Technischer Support und Dokumentation für Cisco Systeme](#)
- [Konfigurationsanleitung für das Netzwerkmanagement, Cisco IOS XE Amsterdam 17.3.x \(Catalyst 9500 Switches\) ERSPAN](#)
- [Konfigurationsanleitung für das Netzwerkmanagement, Cisco IOS XE Amsterdam 17.3.x \(Catalyst 9500 Switches\) SPAN](#)
- [Blog: Transformation der Dokumentation und Vereinfachung des Self-Service mit Cisco TAC](#)

Informationen zu dieser Übersetzung

Cisco hat dieses Dokument maschinell übersetzen und von einem menschlichen Übersetzer editieren und korrigieren lassen, um unseren Benutzern auf der ganzen Welt Support-Inhalte in ihrer eigenen Sprache zu bieten. Bitte beachten Sie, dass selbst die beste maschinelle Übersetzung nicht so genau ist wie eine von einem professionellen Übersetzer angefertigte. Cisco Systems, Inc. übernimmt keine Haftung für die Richtigkeit dieser Übersetzungen und empfiehlt, immer das englische Originaldokument (siehe bereitgestellter Link) heranzuziehen.